

Helsinki Channel Sounding Campaign Report

Tuck Yeen Poon (BBC R&D)
22nd March 2011

Introduction

A high-power 2-by-2 cross-polar MIMO channel sounding campaign was carried out in the city of Helsinki, Finland, as part of the DVB-NGH MIMO investigation. This was carried out in collaboration with Digita, Elektrobit, Nokia, Tampere University and Turku University of Applied Sciences (TUAS) which are involved with the Celtic ENGINES project. Amphenol has kindly assist in the sounding by providing an application antenna. The channel sounding campaign was scheduled for 5 days starting from Monday the 28th of June 2010. The data collected from the measurement campaign will be processed to obtain a realistic 2-by-2 cross-polar MIMO channel model to be used in simulation for technical proposal evaluation.

Locations

The channel data was recorded in 4 different locations:

1. Digita office (indoor and outdoor)
2. Outdoor measurement at the Helsinki Olympic stadium car park (outdoor)
3. Tekes office (indoor and outdoor walkway)
4. High power non-line-of-sight outdoor (near Pasila Tower / Tekes office)

These locations are indicated in Figure 1 below along with the location of the transmitting tower.

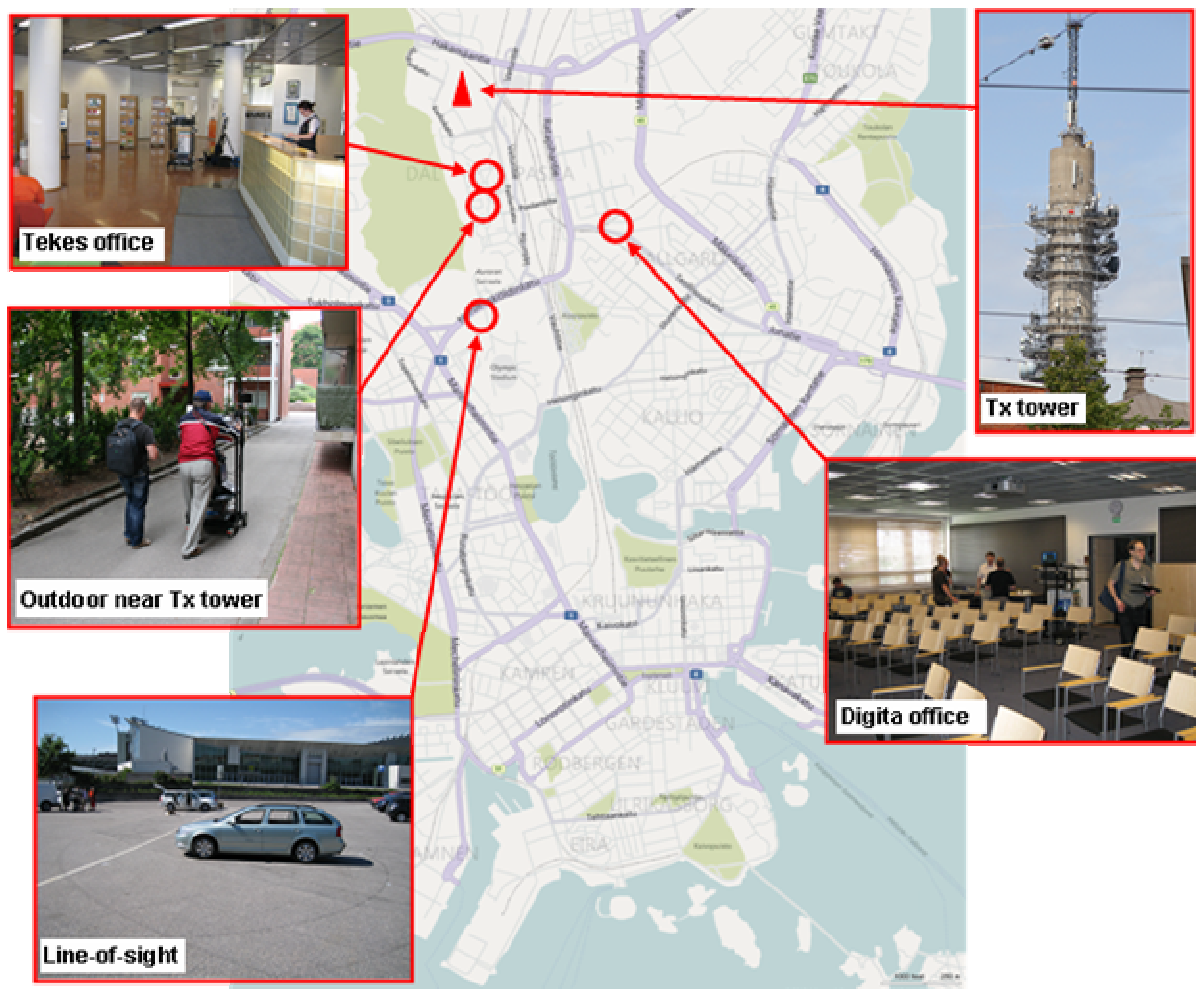

Figure 1: Locations where measurements were taken

Block Diagram Setup

The equipment for the channel sounding was contributed by several partners and the setup can be summarised in the block diagram as shown in Figure 2. The main equipment contributors are as follow :-

- 1) Modulator : BBC R&D
- 2) Power Amplifier : Digita Oy
- 3) Transmit antennas : Digita Oy
- 4) Application antennas :
 - i. Amphenol
 - ii. BBC
 - iii. Nokia
 - iv. TUAS (x2)
- 5) Channel Recorder (data capture) : Elektrobit
- 6) MIMO Receiver (channel display) : BBC R&D

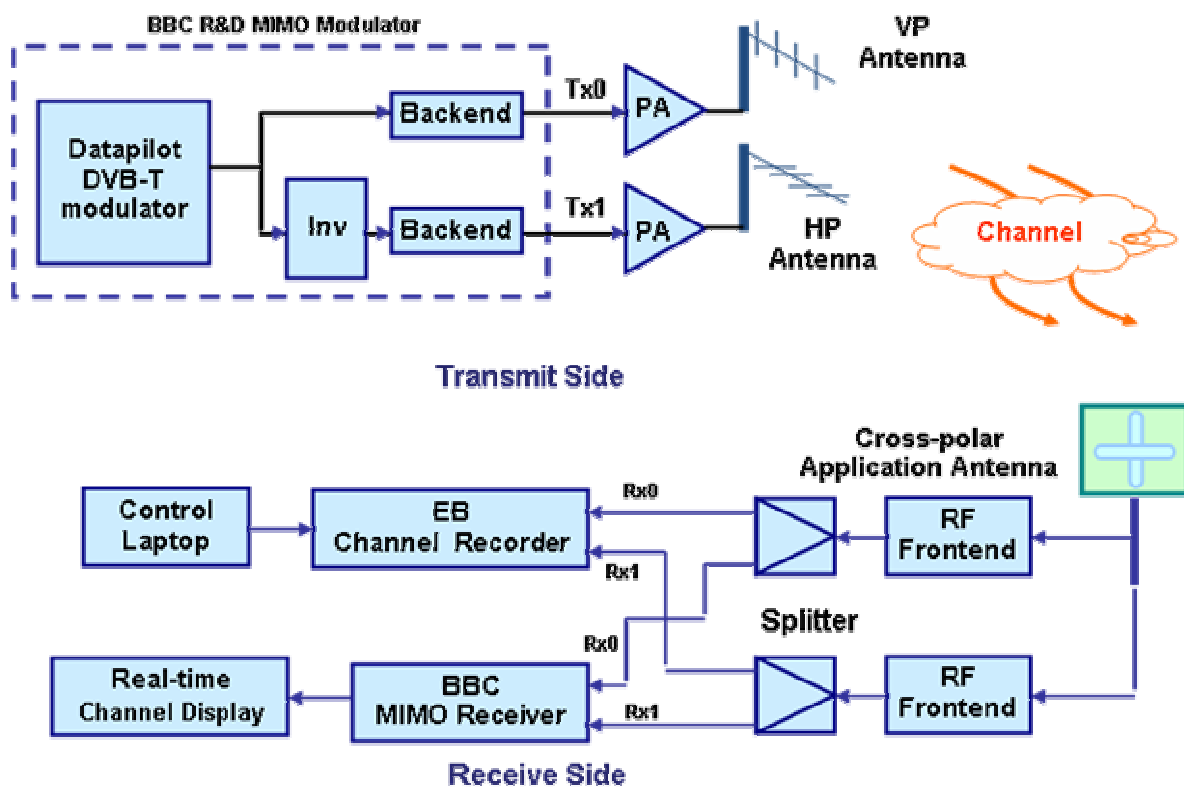

Figure 2 : Block diagram of channel sounding setup

Application Antennas

5 application antennas (referred to APP1, APP2, APP3, APP4 and APP5 during the campaign) were used with Elektrobit’s data capture receiver to record the channel. These antennas were provided by Amphenol, Nokia, TUAS and BBC as stated earlier.

Transmitter

The Pasila Tower was used to transmit the data pilots in both the horizontal and vertical polarised plane. It is situated at the north of the city as indicated in Figure 1. The horizontal and vertical antennas mounted on the transmitting tower are shown in Figure 4. This transmitting tower is approximately 146m above ground level with the technical equipment located at the height of 112m.

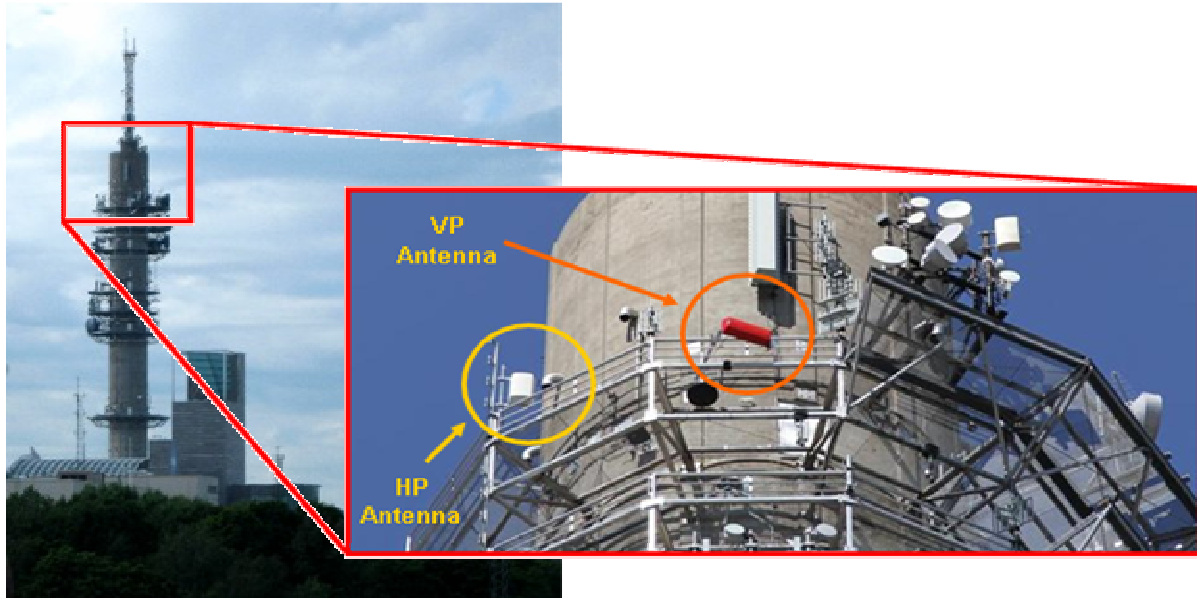

Figure 4: Transmitter Tower (Pasila)

Modulator

The modulator's firmware has been programmed to output pilot data as described in the signal specification [1]. This document is available to all involved in the sounding campaign and it is basically based on DVB-T specification with the data carriers modulated in a predefined long PRBS sequence. The PRBS has a sequence length of $2^{23}-1$ with the generator polynomial $X^{23}+X^{18}+1$.

The equipment setup inside the transmitting tower is shown in Figure 3. The output of the power amplifiers were checked to ensure equal power output. It was recorded during the campaign that the output power from the amplifiers are +41.6 dBm.

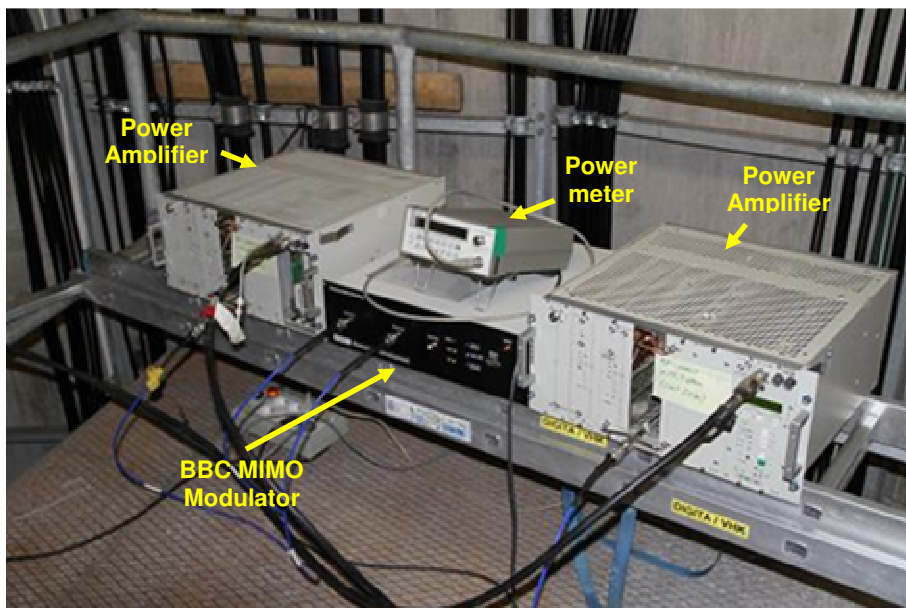
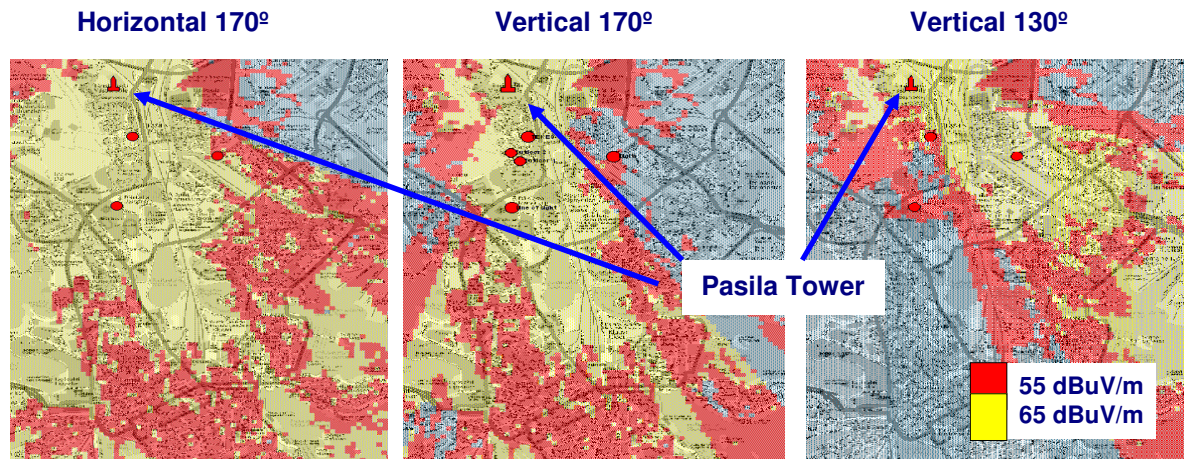

Figure 3: Modulator setup inside the transmitting tower

Coverage Prediction

The individual coverage prediction for the horizontal and vertical antennas at 1.5m above ground is shown in Figure 3. The horizontal panel antenna was able to cover all the locations specified in this sounding campaign, however the vertical antenna has a much narrower beam-width and hence a panning mechanism was built into the VP antenna setup.



* provided by Digita

Figure 5: Coverage prediction on both the horizontal and vertical antennas

Portable Receiver (for data capture)

The portable receiving station was put together as shown in Figure 6 and it consists of the Elektrobit channel recorder (connected to the control laptop), BBC MIMO receiver with real-time channel display, cross-polar application antenna and batteries to power up all the equipment. All these were mounted on a push trolley and the application antenna was mounted on an 'extended-arm' to minimise interference from the equipment. The antenna was about 1.5 meters above ground. The real-time channel display was very useful to give an instant feedback of the channel response and to ensure the integrity of the captured data

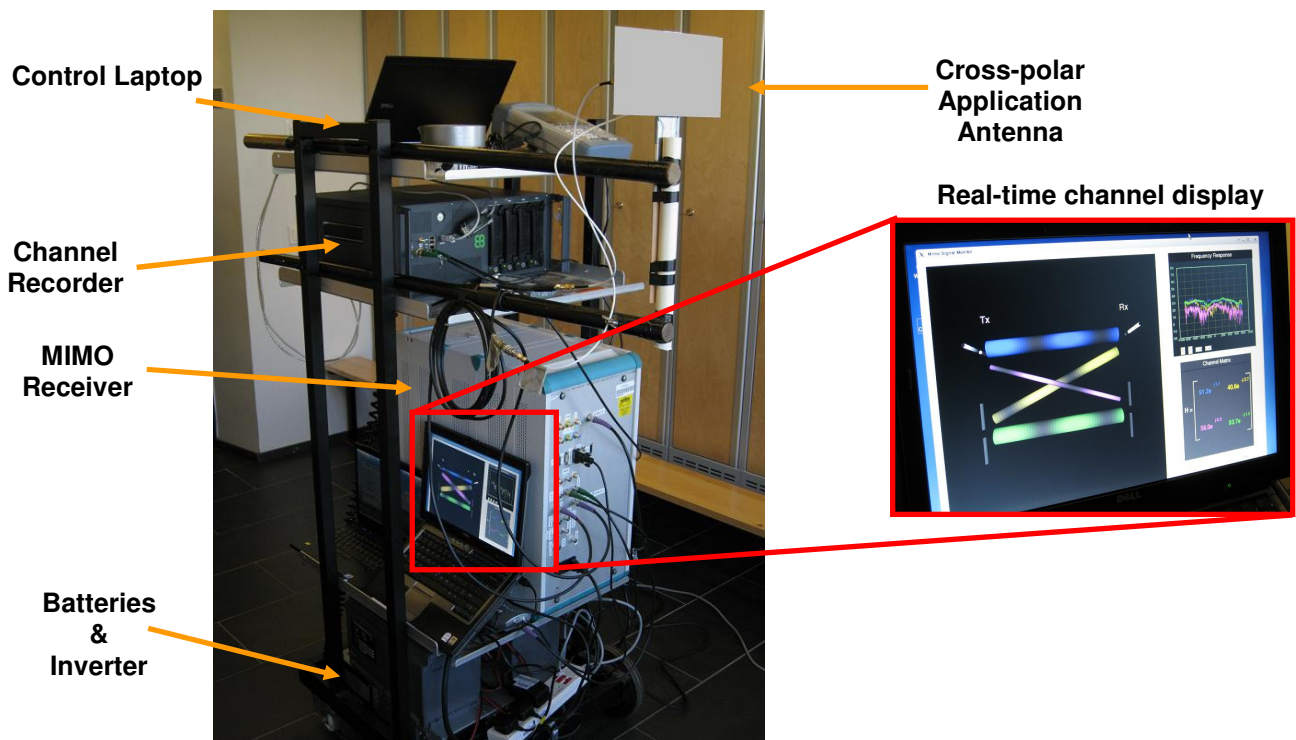

Figure 5: Portable receiving station

Campaign Schedule

The channel sounding campaign schedule is as follow:

- Day 1 (28th June 2010)
 - o Sounding campaign planning
 - o Equipment setup and check
 - o Rebuilding of real-time receiver
 - o Basic setup test inside Digita office
- Day 2 (29th June 2010)
 - o Real measurement recording in Digita office
 - o Measurement outside Digita office
- Day 3 (30th June 2010)
 - o Calibration
 - o Measurement at Olympic stadium car park
 - o Indoor & outdoor measurement at the Tekes office
- Day 4 (1st July 2010)
 - o Strong non-line-of-sight (NLOS) outdoor measurement near Pasila tower / Tekes office
 - o Dismantling setup
- Day 5 (2nd July 2010)
 - o Packing and calibration by Elektorbit

At every location, the data capture receiver will follow a specified route where it was repeated with all the five application antennas. At every location, a 6th run was done with the first application antenna mounted in order to check if there are any anomalies during the measurement runs.

Channel Model

After collecting all the sounding data, the BBC R&D was heavily involved in processing the data to create the necessary channel models for DVB-NGH. Elektorbit, Digita and Tampere University assisted in the initial stages of post-processing while Technische Universität Braunschweig (TU-BS) provided valuable input to the refinement and validation of the channel model. There are also other contributors from the TM-H group in the final Helsinki2 Channel Models document [2].

After analysing all the data, it was proposed that there will be two channel models; Portable Indoor (PI) and Portable Outdoor (PO), for the MIMO configuration in DVB-NGH. Please refer to [2] for full description of the channel models proposed.

References

- [1] channel_sounding_signal_definition_05.pdf
- [2] TM-NGH063r5_DVB-NGH_Helsinki2_channel_models_1v5.pdf