



T2-MI Analyzer Tool for DVB-T2

T2-MI ANALYZER TOOL FOR DVB-T2



T2-MI Analyzer Tool for DVB-T2

Abstract – This paper presents a tool for monitoring and analysing T2-MI signal in the DVB-T2 domain developed by La Salle. T2-MI Analyzer allows monitoring the T2-MI signal generated by a T2-Gateway. The tool also allows the capture of the input signal (ASI or IP) to file for detailed analysis of header and payload bits as specified by DVB-T2 for T2-MI.



Table of Contents

1	DVB-T2 System overview	4
2	T2-MI Packets	5
3	T2-MI Analyzer tool.....	7
	References	14

1 DVB-T2 SYSTEM OVERVIEW

In DVB-T2, the use of Physical Layer Pipes (PLPs) allows a service-specific robustness.

T2-Gateway takes decisions on allocation and scheduling to enable Single Frequency Network (SFN) operation. The signal generated by T2-Gateway is specifically distributed to each modulator in the network in such a format that can unambiguously create an identical on-air signal.

One or more input streams are taken by T2-Gateway to generate un-coded Baseband frames and L1 signalling information that is sent over the T2-MI.

For the T2 system, RF signal is generated by the T2-Modulator. It uses all T2-MI data to perform error coding, frame building and modulation operations.

The construction of reliable networks of transmitters (in both MFN and SFN configurations) is achieved through DVB-T2 Modulator Interface (T2-MI).

Figure 1-1 shows the block diagram of a typical DVB-T2 end-to-end chain for Transport Stream. “Interface B” corresponds to T2-MI, at the output of the T2-Gateway.

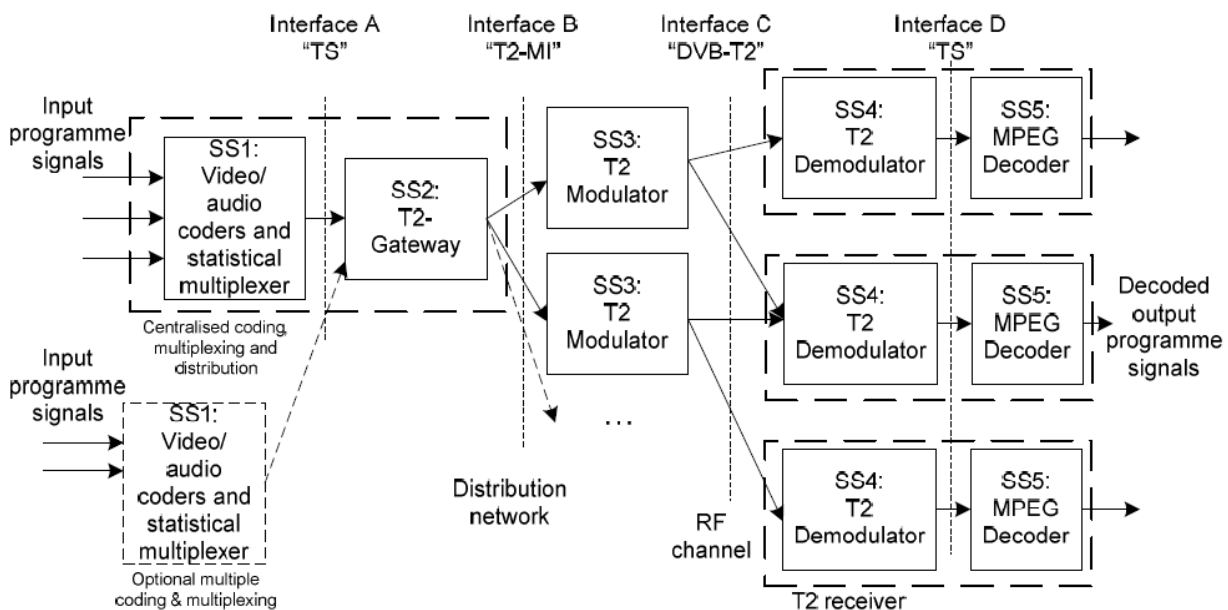

Figure 1-1 Block diagram of a typical DVB-T2 chain

DVB-T2 Baseband Frames encapsulate the DVB-T2 system inputs (TS and/or Generic Streams). These DVB-T2 Baseband Frames are carried in the DVB-T2 Modulator Interface (T2-MI).

Apart from this information, T2-MI also carries other T2 data:

- L1 signalling data: It enables the construction of T2 frames by the modulator.
- IQ vector data: for any auxiliary streams.
- DVB-T2 timestamp: for synchronization issues.
- Future Extension Frame (FEF) data.

All this information is transmitted in the on-air DVB-T2 signal, except the DVB-T2 timestamp packets.

A modulator uses the synchronization timestamp data to define the precise time of DVB-T2 signal emission.

First, T2 data is packetized into T2-MI packets, and then T2-MI packets are encapsulated into DVB/MPEG Transport Stream packets using Data Piping.

The DVB TS packets are natively carried over any standard DVB Transport Stream interface (ASI). Also, it can be encapsulated within IP packets over IP based networks.

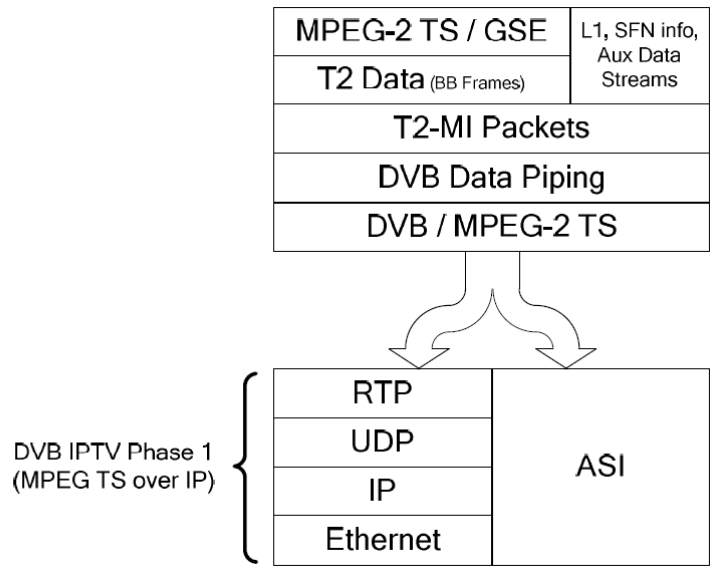

Figure 1-2 The T2-MI protocol stack

2 T2-MI PACKETS

T2-MI allows the transmission of several different types of T2-related data through T2-MI packets.

Figure 2-1 shows the T2-MI packet format.

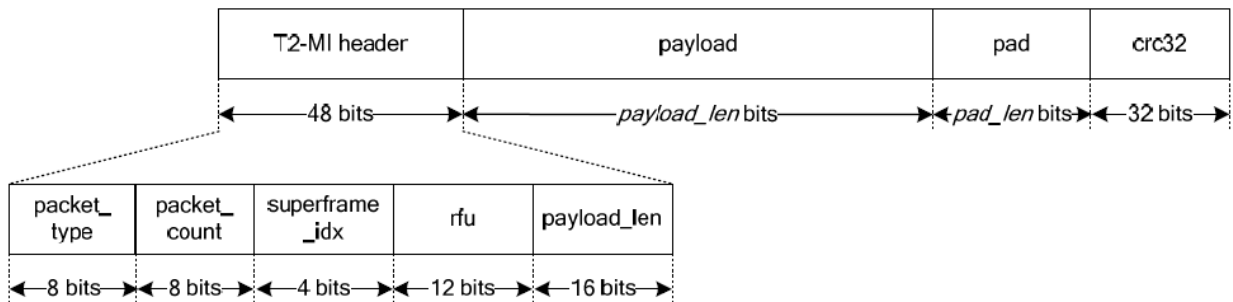

Figure 2-1 T2-MI packet format



T2-MI Analyzer Tool for DVB-T2

A T2-MI packet has a header of 6 bytes, a variable-length payload plus padding bits (when required), and a 32-bit CRC for error detection at the end.

Currently the following T2-MI packet types are defined associated with carrying payload:

- Baseband Frame
- Auxiliary stream I/Q data
- Arbitrary cell insertion
- L1-current
- L1-future
- P2 bias balancing cells
- DVB-T2 timestamp
- Individual addressing
- FEF part: Null
- FEF part: I/Q data
- FEF part: composite
- FEF sub-part

3 T2-MI ANALYZER TOOL

T2-MI Analyzer developed by LaSalle is a tool for monitoring and analysing T2-MI signal in the DVB-T2 domain.

Figure 3-1 shows schematically a block diagram of the T2-MI Analyzer tool. T2-MI signal is generated by a DVB-T2 Gateway. This equipment is capable of generating the output signal in three ways: ASI, IP or save it to file. The diagram shows a first block which corresponds to the Input Interface that accepts all three types of T2-MI signal. After configuring the type of input signal with which to work, T2-MI Analyzer starts in monitoring mode, for ASI and IP, and in analysis mode for file input. Monitoring mode displays the basic configuration parameters of the T2-MI signal and allows the user to capture a T2-MI signal to a file. Analysis mode shows in detail the different T2-MI packets (header and payload) and can extract the PLPs transported in Baseband Frame packets and save them to TS files.

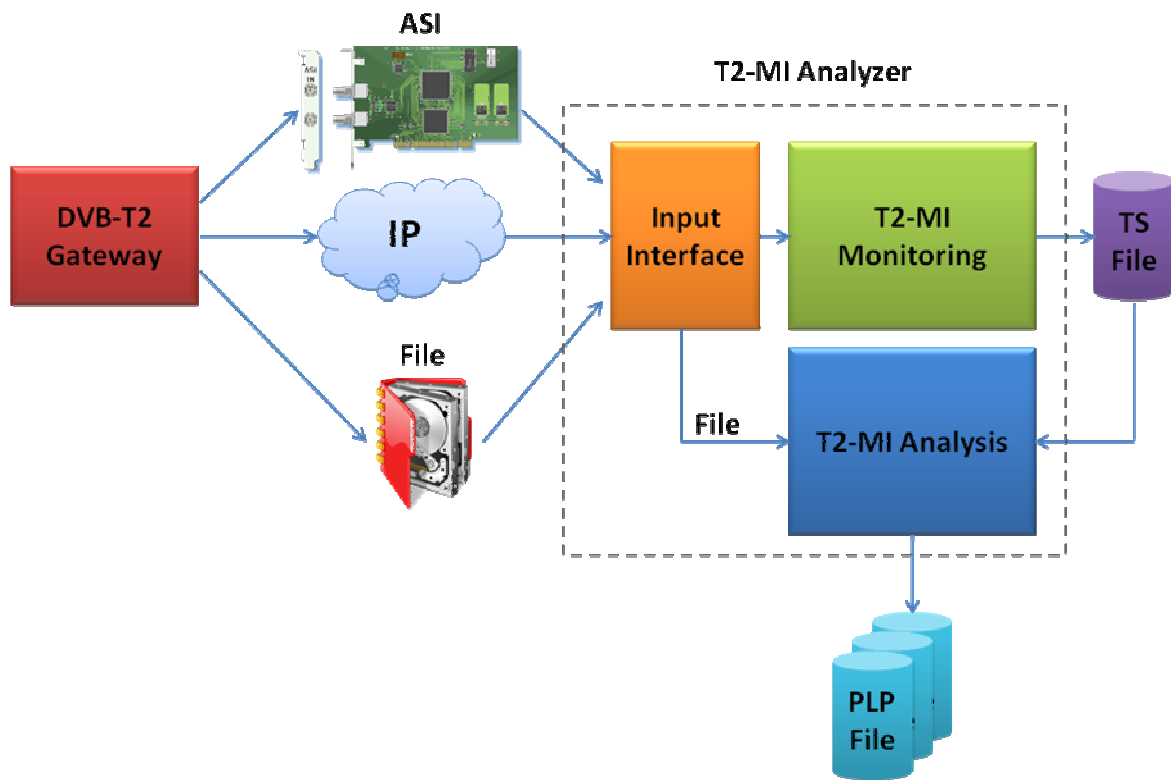

Figure 3-1 T2-MI Analyzer tool block diagram scheme

As explained above, the T2-MI Analyzer tool has two basic operating modes. Firstly it is a T2-MI signal monitoring tool. The application allows three input types: ASI, IP and file.

Figure 3-2 shows an application screenshot where user can select the type of input signal (ASI, IP or file).

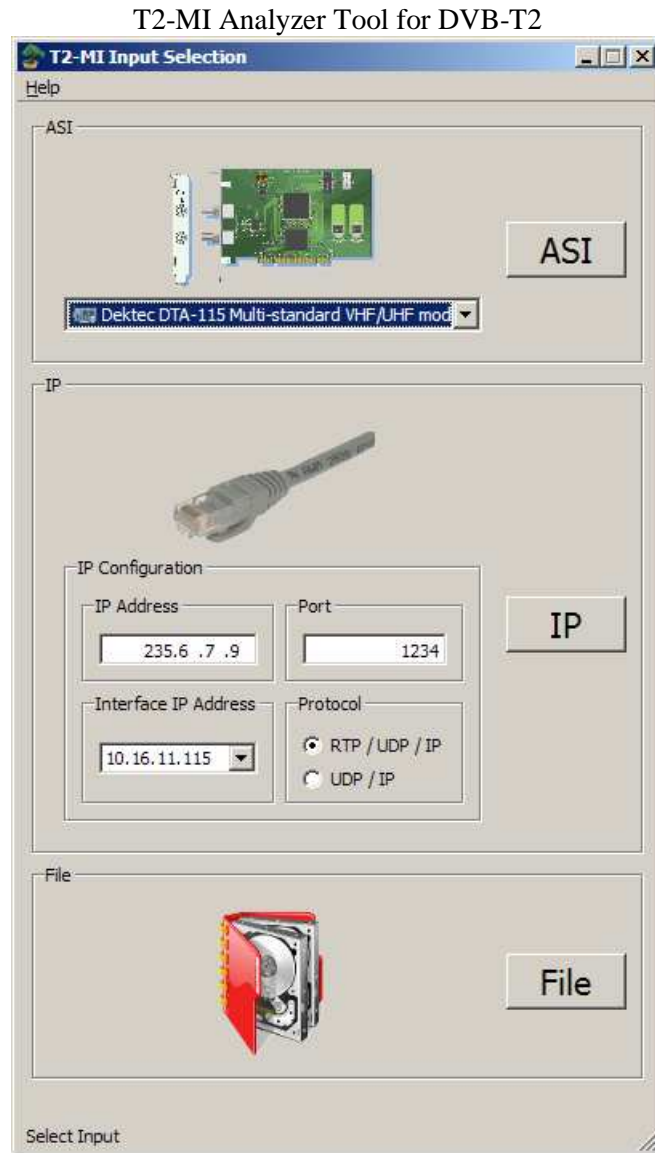
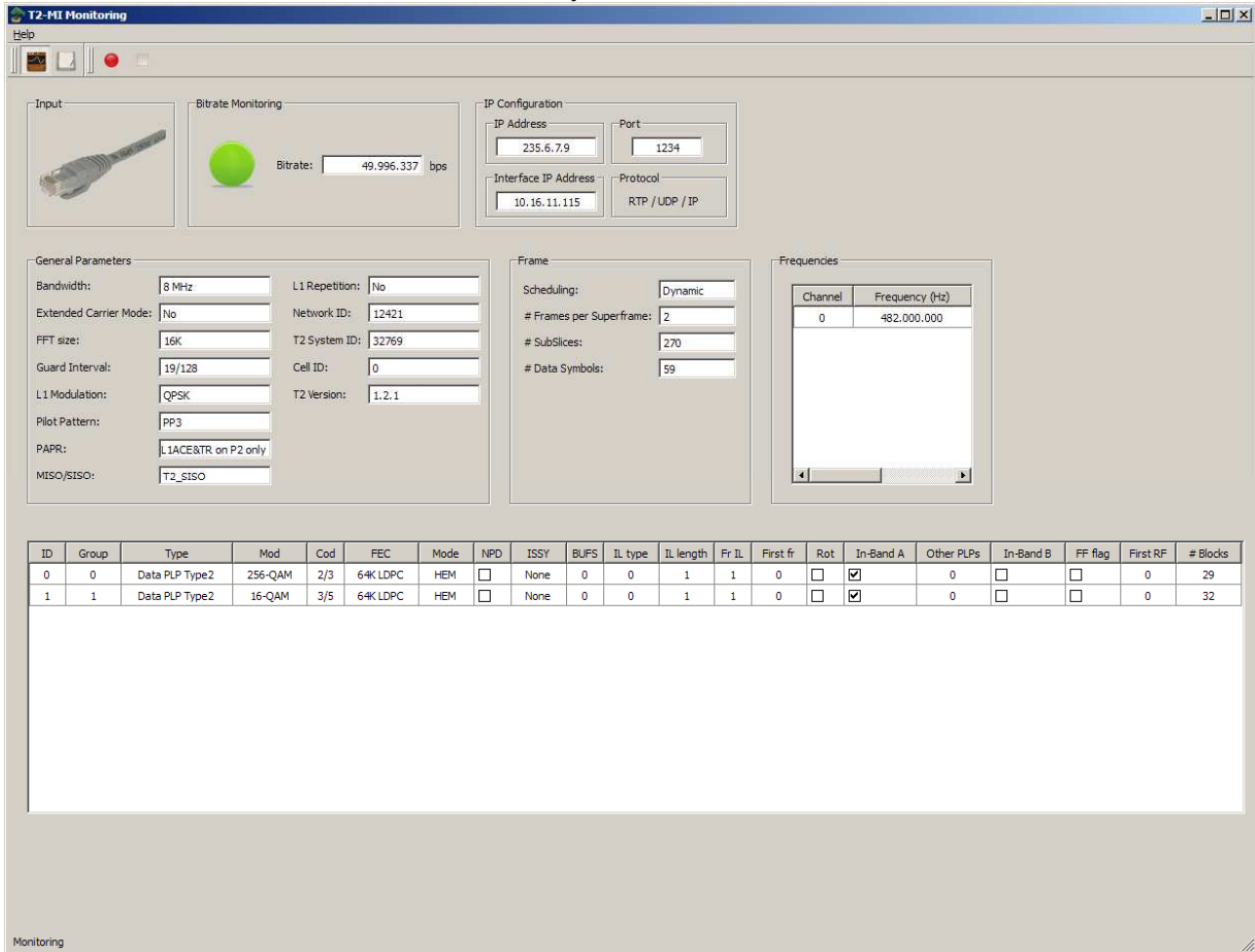

Figure 3-2 T2-MI Analyzer – Input Selection Frame

For monitoring functionality, T2-MI signal is only meaningful for ASI and IP input signal types. This feature analyzes the input T2-MI signal in real-time and detects the configuration parameters, as shown in

Figure 3-3.



The screenshot shows the 'T2-MI Monitoring' application window. It features several configuration panels:

- Input:** Shows a network cable icon.
- Bitrate Monitoring:** Displays a green sphere and a bitrate of 49,996,337 bps.
- IP Configuration:** Includes fields for IP Address (235.6.7.9), Port (1234), Interface IP Address (10.16.11.115), and Protocol (RTP / UDP / IP).
- General Parameters:** Contains fields for Bandwidth (8 MHz), Extended Carrier Mode (No), FFT size (16K), Guard Interval (19/128), L1 Modulation (QPSK), Pilot Pattern (PP3), PAPR (L1ACE&TR on P2 only), and MISO/SISO (T2_SISO).
- Frame:** Includes fields for Scheduling (Dynamic), # Frames per Superframe (2), # SubSlices (270), and # Data Symbols (59).
- Frequencies:** A table showing Channel 0 at Frequency 482,000,000 Hz.
- Data Table:** A table with columns: ID, Group, Type, Mod, Cod, FEC, Mode, NPD, ISSY, BUFS, IL type, IL length, Fr IL, First fr, Rot, In-Band A, Other PLPs, In-Band B, FF flag, First RF, # Blocks. It contains two rows of data.

ID	Group	Type	Mod	Cod	FEC	Mode	NPD	ISSY	BUFS	IL type	IL length	Fr IL	First fr	Rot	In-Band A	Other PLPs	In-Band B	FF flag	First RF	# Blocks
0	0	Data PLP Type2	256-QAM	2/3	64K LDPC	HEM	<input type="checkbox"/>	None	0	0	1	1	0	<input type="checkbox"/>	<input checked="" type="checkbox"/>	0	<input type="checkbox"/>	<input type="checkbox"/>	0	29
1	1	Data PLP Type2	16-QAM	3/5	64K LDPC	HEM	<input type="checkbox"/>	None	0	0	1	1	0	<input type="checkbox"/>	<input checked="" type="checkbox"/>	0	<input type="checkbox"/>	<input type="checkbox"/>	0	32

Figure 3-3 T2-MI Analyzer – T2-MI Monitoring – IP input signal

It is also possible to capture the input signal, for both ASI and IP input, to a file. After this capture, T2-MI data contained in captured file can be analyzed in more detail. As mentioned above, the T2-MI signal is encapsulated on MPEG TS packets, therefore, in an intermediate step, a T2-MI signal decapsulation (Data Piping decapsulation) is performed to T2-MI packets.

Once obtained these T2-MI packets, the tool allows a detailed bit and/or byte analysis for header and payload of T2-MI packets. The application presents a friendly user interface to navigate through the different types of T2-MI packets and to read the header fields and payload bytes contained (

Figure 3-4).

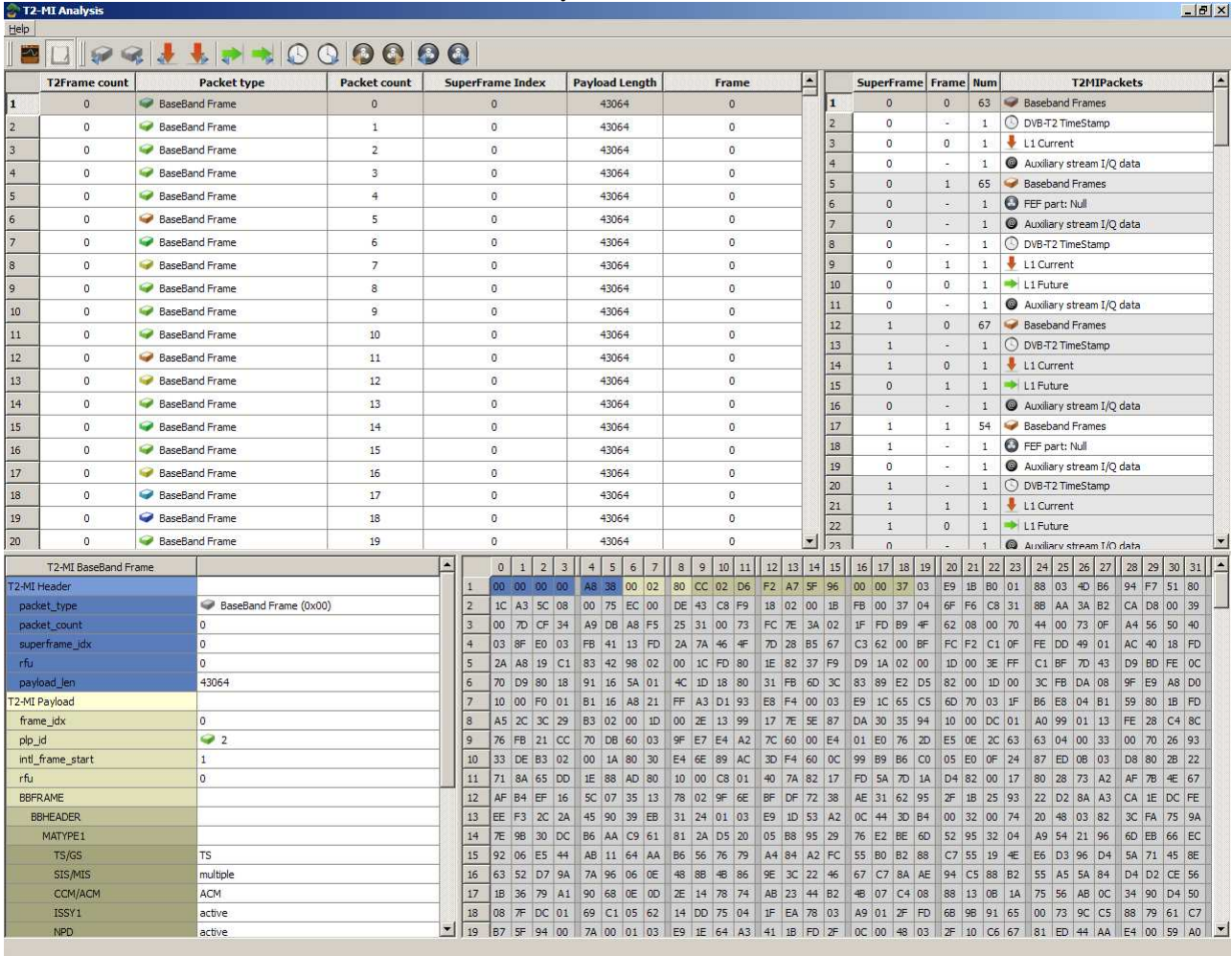

Figure 3-4 T2-MI Analyzer – Analysis Mode

Finally, the T2-MI Analyzer tool allows the regeneration of different PLPs carried in the Baseband frames that are transmitted in T2-MI signal.

In analysis mode, the frame at the top right shows a T2-Frames navigation, which can be seen as a list of the type of T2-MI packets carried in each T2-Frame. Figure 3-5 shows an example of the T2-MI Navigator.

T2-MI Analyzer Tool for DVB-T2

	SuperFrame	Frame	Num	T2MIPackets
1	0	0	63	Baseband Frames
2	0	-	1	DVB-T2 TimeStamp
3	0	0	1	L1 Current
4	0	-	1	Auxiliary stream I/Q data
5	0	1	65	Baseband Frames
6	0	-	1	FEF part: Null
7	0	-	1	Auxiliary stream I/Q data
8	0	-	1	DVB-T2 TimeStamp
9	0	1	1	L1 Current
10	0	0	1	L1 Future
11	0	-	1	Auxiliary stream I/Q data
12	1	0	67	Baseband Frames
13	1	-	1	DVB-T2 TimeStamp
14	1	0	1	L1 Current
15	0	1	1	L1 Future
16	0	-	1	Auxiliary stream I/Q data
17	1	1	54	Baseband Frames
18	1	-	1	FEF part: Null
19	0	-	1	Auxiliary stream I/Q data
20	1	-	1	DVB-T2 TimeStamp
21	1	1	1	L1 Current
22	1	0	1	L1 Future
23	0	-	1	Auxiliary stream I/Q data

Figure 3-5 T2-MI Analyzer – T2-Frame Navigator

The frame of the upper left lists all the T2-MI packets as shown in Figure 3-6. The different colours of the icons that label the Baseband Frame indicate different PLP ID.

	T2Frame count	Packet type	Packet count	SuperFrame Index	Payload Length	Frame
52	0	BaseBand Frame	51	0	43064	0
53	0	BaseBand Frame	52	0	43064	0
54	0	BaseBand Frame	53	0	43064	0
55	0	BaseBand Frame	54	0	43064	0
56	0	BaseBand Frame	55	0	43064	0
57	0	BaseBand Frame	56	0	43064	0
58	0	BaseBand Frame	57	0	43064	0
59	0	BaseBand Frame	58	0	43064	0
60	0	BaseBand Frame	59	0	10656	0
61	0	BaseBand Frame	60	0	10656	0
62	0	BaseBand Frame	61	0	43064	0
63	0	BaseBand Frame	62	0	43064	0
64	0	DVB-T2 TimeStamp	63	0	88	-
65	0	L1 Current	64	0	1408	0
66	0	Auxiliary stream I/Q data	25	0	72	-
67	1	BaseBand Frame	65	0	43064	1
68	1	BaseBand Frame	66	0	43064	1
69	1	BaseBand Frame	67	0	43064	1
70	1	BaseBand Frame	68	0	43064	1
71	1	BaseBand Frame	69	0	43064	1

Figure 3-6 T2-MI Analyzer – T2-MI Packets list

The lower left frame (Figure 3-7) shows in detail the T2-MI packet: T2-MI Header, T2-MI Payload, padding bits and CRC32. The T2-MI packet that is displayed corresponds to the selected T2-MI packet in the list of T2-MI packets (Figure 3-6).

T2-MI Analyzer Tool for DVB-T2

T2-MI BaseBand Frame	
T2-MI Header	
packet_type	BaseBand Frame (0x00)
packet_count	0
superframe_idx	0
rfu	0
payload_len	43064
T2-MI Payload	
frame_idx	0
plp_id	2
intf_frame_start	1
rfu	0
BBFRAME	
BBHEADER	
MATYPE1	
TS/GS	TS
SIS/MIS	multiple
CCM/ACM	ACM
ISSY1	active
NPD	active
EXT	0
MATYPE2	
ISSY 2MSB	55026
DFL	42847
ISSY 1LSB	150
SYNCD	0
CRC-8 MODE	55
DATA FIELD	03 E9 1B B0 ...
PADDING AND/OR INBAND SIGN...	113 bits
crc32	91 F3 00 A2

Figure 3-7 T2-MI Analyzer – T2-MI Packet fields

T2-MI Payload shows the different fields depending on T2-MI packet type. The types of T2-MI packets that can be parsed and displayed are:

- Baseband Frame
- Auxiliary stream I/Q data
- Arbitrary cell insertion
- L1-current
- L1-future
- P2 bias balancing cells
- DVB-T2 timestamp
- Individual addressing
- FEF part: Null
- FEF part: I/Q data
- FEF part: composite
- FEF sub-part

Figure 3-8 correspond to the lower right frame. It shows all the bytes (in hex) of selected T2-MI packet. Background colours indicate the bytes of header, payload, padding and CRC32.



T2-MI Analyzer Tool for DVB-T2

	0	1	2	3	4	5	6	7	8	9	10	11	12	13	14	15	16	17	18	19	20	21	22	23	24	25	26	27	28	29	30	31
1	10	40	00	00	05	80	00	00	00	8F	40	20	00	D3	80	49	66	00	00	00	30	85	80	01	02	01	B0	20	40	02	F7	00
2	D8	0E	00	00	72	EA	F2	00	01	34	00	02	00	43	00	00	04	E8	72	02	02	80	04	00	A1	80	00	02	74	39	01	01
3	40	02	00	90	C0	00	01	3A	1C	80	80	A0	01	00	68	60	00	00	9D	0E	40	40	50	00	80	40	30	00	00	4A	04	60
4	20	28	00	40	2A	18	00	00	27	43	90	10	14	00	20	19	0C	00	00	13	A1	C8	08	0A	00	10	00	00	00	00	01	9F
5	00	00	46	50	01	FA	40	00	00	00	00	FD	20	1A	00	02	01	1B	98	18	00	04	01	37	B8	2C	00	06	01	6B	48	0E
6	00	08	00	00	00	06	00	0A	01	7B	B0	06	00	0C	01	82	B8	06	00	00	00	00	8A	88	A5	2A						

Figure 3-8 T2-MI Analyzer – T2-MI Packet bytes (hex)



References

- [1] ETSI TR 102 831 v.0.10.04 (2010-03), "*Digital Video Broadcasting (DVB); Implementation guidelines for a second generation digital terrestrial television broadcasting system (DVB-T2)*", DVB (Digital Video Broadcasting)
- [2] DVB Document A122, "*Digital Video Broadcasting (DVB); Frame structure channel coding and modulation for a second generation digital terrestrial television broadcasting system (DVB-T2)*", June 2010, DVB (Digital Video Broadcasting)
- [3] ETSI TS 102 773 v.1.2.1 (2010-12), "*Digital Video Broadcasting (DVB); Modulator Interface(T2-MI) for a second generation digital terrestrial television broadcasting system (DVB-T2)*", DVB (Digital Video Broadcasting)