

---

# Programming Embedded Systems II

A 10-week course, using C

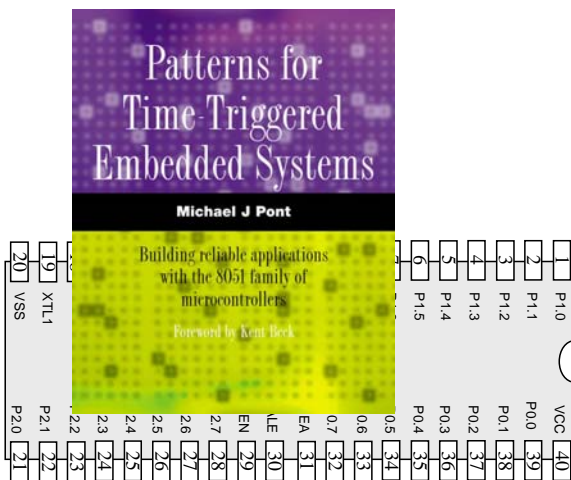

**Michael J. Pont**  
University of Leicester

[v2.1]

Further info:

<http://www.le.ac.uk/engineering/mjp9/>

---

**Copyright © Michael J. Pont, 2002-2006**

This document may be freely distributed and copied, provided that copyright notice at the foot of each OHP page is clearly visible in all copies.

---

<b>Seminar 1:</b>	<b>1</b>
<b>Seminar 2: A flexible scheduler for single-processor embedded systems</b>	<b>1</b>
Overview of this seminar	2
Overview of this course	3
By the end of the course you'll be able to ...	4
Main course text	5
IMPORTANT: Course prerequisites	6
Review: Why use C?	7
Review: The 8051 microcontroller	8
Review: The "super loop" software architecture	9
Review: An introduction to schedulers	10
Review: Building a scheduler	11
Overview of this seminar	12
The Co-operative Scheduler	13
Overview	14
The scheduler data structure and task array	15
The size of the task array	16
One possible initialisation function:	17
IMPORTANT: The 'one interrupt per microcontroller' rule!	18
The 'Update' function	19
The 'Add Task' function	20
The 'Dispatcher'	22
Function arguments	24
Function pointers and Keil linker options	25
The 'Start' function	28
The 'Delete Task' function	29
Reducing power consumption	30
Reporting errors	31
Displaying error codes	34
Hardware resource implications	35
What is the CPU load of the scheduler?	36
Determining the required tick interval	38
Guidelines for predictable and reliable scheduling	40
Overall strengths and weaknesses of the scheduler	41
Preparations for the next seminar	42

---

<b>Seminar 3: Analogue I/O using ADCs and PWM</b>	<b>43</b>
Overview of this seminar	44
PATTERN: One-Shot ADC	45
PATTERN: One-Shot ADC	46
Using a microcontroller with on-chip ADC	47
Using an external parallel ADC	48
Example: Using a Max150 ADC	49
Using an external serial ADC	51
Example: Using an external SPI ADC	52
Overview of SPI	53
Back to the example ...	54
Example: Using an external I <sup>2</sup> C ADC	55
Overview of I2C	56
Back to the example ...	57
What is PWM?	58
PATTERN: Software PWM	59
Preparations for the next seminar	62

---

<b>Seminar 4: A closer look at co-operative task scheduling (and some alternatives)</b>	<b>63</b>
Overview of this seminar	64
Review: Co-operative scheduling	65
The pre-emptive scheduler	66
Why do we avoid pre-emptive schedulers in this course?	67
Why is a co-operative scheduler (generally) more reliable?	68
Critical sections of code	69
How do we deal with critical sections in a pre-emptive system?	70
Building a “lock” mechanism	71
The “best of both worlds” - a hybrid scheduler	75
Creating a hybrid scheduler	76
The ‘Update’ function for a hybrid scheduler.	78
Reliability and safety issues	81
The safest way to use the hybrid scheduler	83
Other forms of co-operative scheduler	85
PATTERN: 255-TICK SCHEDULER	86
PATTERN: ONE-TASK SCHEDULER	87
PATTERN: ONE-YEAR SCHEDULER	88
PATTERN: STABLE SCHEDULER	89
Mix and match ...	90
Preparations for the next seminar	91

---

<b>Seminar 5: Improving system reliability using watchdog timers</b>	<b>93</b>
Overview of this seminar	94
The watchdog analogy	95
PATTERN: Watchdog Recovery	96
Choice of hardware	97
Time-based error detection	98
Other uses for watchdog-induced resets	99
Recovery behaviour	100
Risk assessment	101
The limitations of single-processor designs	102
Time, time, time ...	103
Watchdogs: Overall strengths and weaknesses	104
PATTERN: Scheduler Watchdog	105
Selecting the overflow period - “hard” constraints	106
Selecting the overflow period - “soft” constraints	107
PATTERN: Program-Flow Watchdog	108
Dealing with errors	110
Hardware resource implications	111
Speeding up the response	112
PATTERN: Reset Recovery	114
PATTERN: Fail-Silent Recovery	115
Example: Fail-Silent behaviour in the Airbus A310	116
Example: Fail-Silent behaviour in a steer-by-wire application	117
PATTERN: Limp-Home Recovery	118
Example: Limp-home behaviour in a steer-by-wire application	119
PATTERN: Oscillator Watchdog	122
Preparations for the next seminar	124

---

<b>Seminar 6: Shared-clock schedulers for multi-processor systems</b>	<b>125</b>
Overview of this seminar	126
Why use more than one processor?	127
Additional CPU performance and hardware facilities	128
The benefits of modular design	130
The benefits of modular design	131
So - how do we link more than one processor?	132
Synchronising the clocks	133
Synchronising the clocks	134
Synchronising the clocks - Slave nodes	135
Transferring data	136
Transferring data (Master to Slave)	137
Transferring data (Slave to Master)	138
Transferring data (Slave to Master)	139
Detecting network and node errors	140
Detecting errors in the Slave(s)	141
Detecting errors in the Master	142
Handling errors detected by the Slave	143
Handling errors detected by the Master	144
Enter a safe state and shut down the network	145
Reset the network	146
Engage a backup Slave	147
Why additional processors may not improve reliability	148
Redundant networks do not guarantee increased reliability	149
Replacing the human operator - implications	150
Are multi-processor designs ever safe?	151
Preparations for the next seminar	152

---

<b>Seminar 7: Linking processors using RS-232 and RS-485 protocols</b>	<b>153</b>
Review: Shared-clock scheduling	154
Overview of this seminar	155
Review: What is 'RS-232'?	156
Review: Basic RS-232 Protocol	157
Review: Transferring data to a PC using RS-232	158
PATTERN: SCU SCHEDULER (LOCAL)	159
The message structure	160
Determining the required baud rate	163
Node Hardware	165
Network wiring	166
Overall strengths and weaknesses	167
PATTERN: SCU Scheduler (RS-232)	168
PATTERN: SCU Scheduler (RS-485)	169
RS-232 vs RS-485 [number of nodes]	170
RS-232 vs RS-485 [range and baud rates]	171
RS-232 vs RS-485 [cabling]	172
RS-232 vs RS-485 [transceivers]	173
Software considerations: enable inputs	174
Overall strengths and weaknesses	175
Example: Network with Max489 transceivers	176
Preparations for the next seminar	177



---

<b>Seminar 8: Linking processors using the Controller Area Network (CAN) bus</b>	<b>179</b>
Overview of this seminar	180
PATTERN: SCC Scheduler	181
What is CAN?	182
CAN 1.0 vs. CAN 2.0	184
Basic CAN vs. Full CAN	185
Which microcontrollers have support for CAN?	186
S-C scheduling over CAN	187
The message structure - Tick messages	188
The message structure - Ack messages	189
Determining the required baud rate	190
Transceivers for distributed networks	192
Node wiring for distributed networks	193
Hardware and wiring for local networks	194
Software for the shared-clock CAN scheduler	195
Overall strengths and weaknesses	196
Example: Creating a CAN-based scheduler using the Infineon C515c	197
Master Software	198
Slave Software	211
What about CAN without on-chip hardware support?	218
Preparations for the next seminar	220

---

<b>Seminar 9: Applying “Proportional Integral Differential” (PID) control</b>	<b>221</b>
Overview of this seminar	222
Why do we need closed-loop control?	223
Closed-loop control	227
What closed-loop algorithm should you use?	228
What is PID control?	229
A complete PID control implementation	230
Another version	231
Dealing with ‘windup’	232
Choosing the controller parameters	233
What sample rate?	234
Hardware resource implications	235
PID: Overall strengths and weaknesses	236
Why open-loop controllers are still (sometimes) useful	237
Limitations of PID control	238
Example: Tuning the parameters of a cruise-control system	239
Open-loop test	241
Tuning the PID parameters: methodology	242
First test	243
Example: DC Motor Speed Control	245
<u>Alternative</u> : Fuzzy control	248
Preparations for the next seminar	249

---

<b>Seminar 10: Case study: Automotive cruise control using PID and CAN</b>	<b>251</b>
Overview of this seminar	252
Single-processor system: Overview	253
Single-processor system: Code	254
Multi-processor design: Overview	255
Multi-processor design: Code (PID node)	256
Multi-processor design: Code (Speed node)	257
Multi-processor design: Code (Throttle node)	258
Exploring the impact of network delays	259
Example: Impact of network delays on the CCS system	260
That's it!	261



---

# Seminar 1:

# Seminar 2:

A flexible scheduler  
for single-processor  
embedded systems

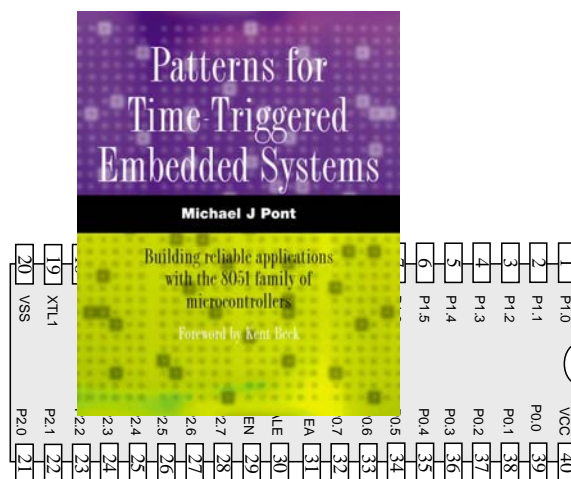

---

## Overview of this seminar

This introductory seminar will run over **TWO SESSIONS**:

It will:

- Provide an overview of this course (this seminar slot)
- Describe the design and implementation of a flexible scheduler (this slot and the next slot)

---

## Overview of this course

This course is primarily concerned with the implementation of software (and a small amount of hardware) for embedded systems constructed using more than one microcontroller.

The processors examined in detail will be from the 8051 family.

All programming will be in the 'C' language  
(using the Keil C51 compiler)

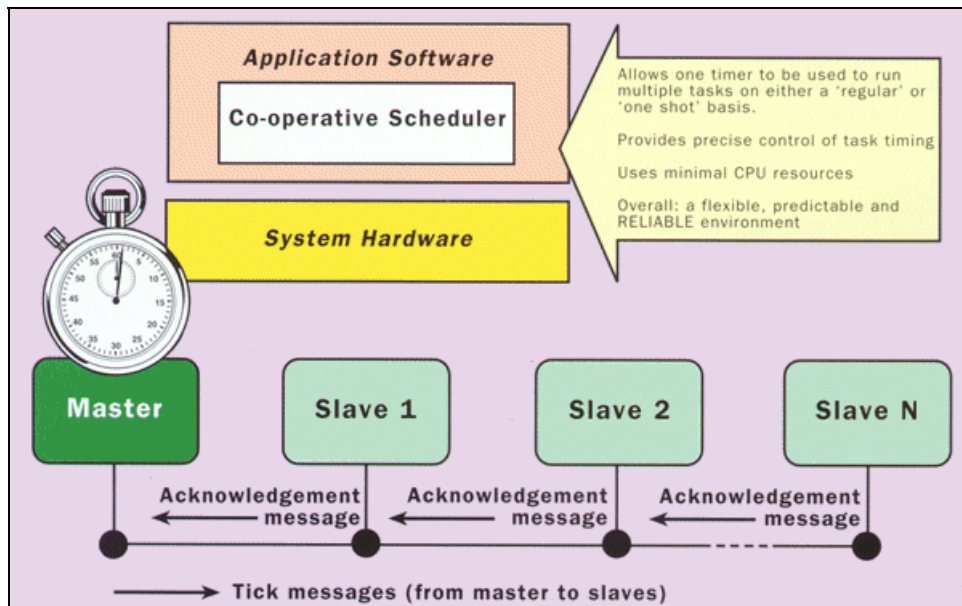

---

## By the end of the course you'll be able to ...

By the end of the course, you will be able to:

1. Design software for multi-processor embedded applications based on small, industry standard, microcontrollers;
2. Implement the above designs using a modern, high-level programming language ('C'), and
3. Understand more about the effect that software design and programming designs can have on the reliability and safety of multi-processor embedded systems.



---

## Main course text

Throughout this course, we will be making heavy use of this book:

*Patterns for time-triggered embedded systems: Building reliable applications with the 8051 family of microcontrollers,*

by Michael J. Pont (2001)

Addison-Wesley / ACM Press.  
[ISBN: 0-201-331381]

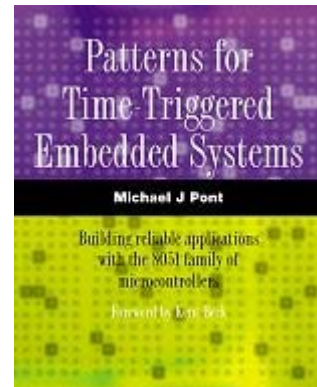

For further details, please see:

<http://www.engg.le.ac.uk/books/Pont/pttes.htm>

## IMPORTANT: Course prerequisites

- It is assumed that - **before taking** this course - you have previously completed “Programming Embedded Systems I” (or a similar course).

See:

[www.le.ac.uk/engineering/mjp9/pttesguide.htm](http://www.le.ac.uk/engineering/mjp9/pttesguide.htm)

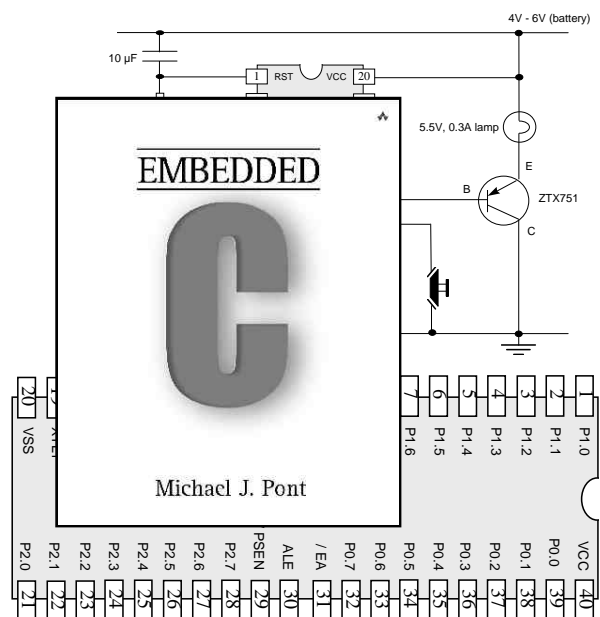

---

## Review: Why use C?

- It is a ‘mid-level’ language, with ‘high-level’ features (such as support for functions and modules), and ‘low-level’ features (such as good access to hardware via pointers);
- It is very efficient;
- It is popular and well understood;
- Even desktop developers who have used only Java or C++ can soon understand C syntax;
- Good, well-proven compilers are available for every embedded processor (8-bit to 32-bit or more);
- Experienced staff are available;
- Books, training courses, code samples and WWW sites discussing the use of the language are all widely available.

Overall, C may not be an ideal language for developing embedded systems, but it is a good choice (and is unlikely that a ‘perfect’ language will ever be created).

---

## Review: The 8051 microcontroller

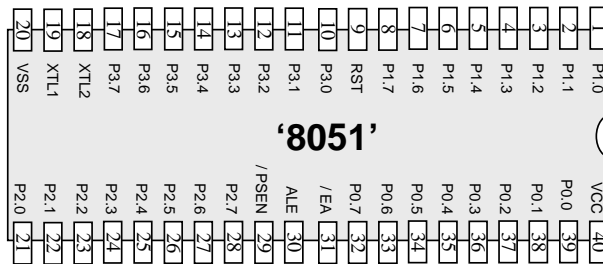

Typical features of a modern 8051:

- Thirty-two input / output lines.
- Internal data (RAM) memory - 256 bytes.
- Up to 64 kbytes of ROM memory (usually flash)
- Three 16-bit timers / counters
- Nine interrupts (two external) with two priority levels.
- Low-power Idle and Power-down modes.

The different members of the 8051 family are suitable for a huge range of projects - from automotive and aerospace systems to TV “remotes”.

---

## Review: The “super loop” software architecture

### Problem

What is the minimum software environment you need to create an embedded C program?

### Solution

```
void main(void)
{
    /* Prepare for Task X */
    X_Init();

    while(1) /* 'for ever' (Super Loop) */
    {
        X(); /* Perform the task */
    }
}
```

Crucially, the ‘super loop’, or ‘endless loop’, is required because we have no operating system to return to: our application will keep looping until the system power is removed.

---

## Review: An introduction to schedulers

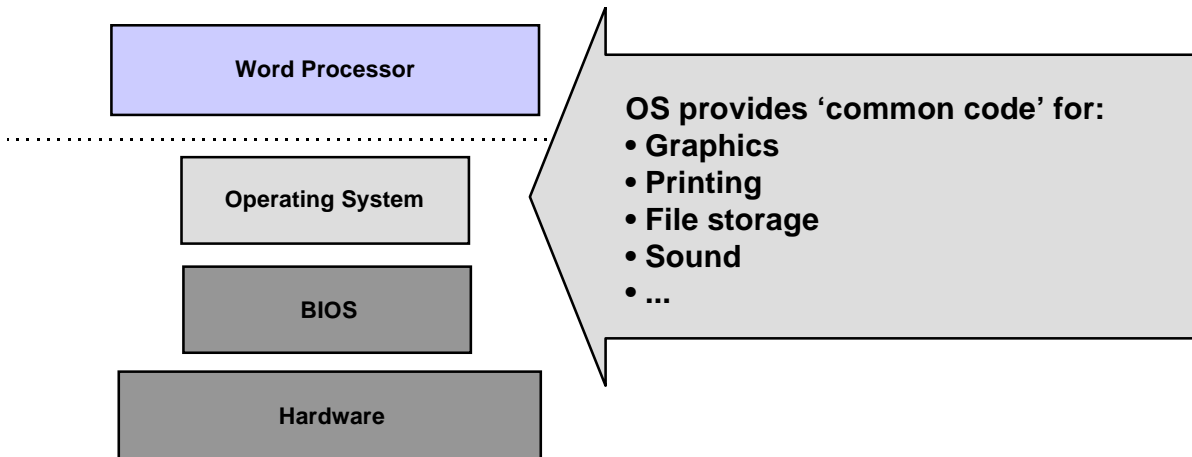

Many embedded systems must carry out tasks at particular instants of time. More specifically, we have two kinds of activity to perform:

- **Periodic tasks**, to be performed (say) once every 100 ms, and - less commonly -
- **One-shot tasks**, to be performed once after a delay of (say) 50 ms.

---

## Review: Building a scheduler

```
void main(void)
{
    Timer_2_Init(); /* Set up Timer 2 */

    EA = 1;          /* Globally enable interrupts */

    while(1);       /* An empty Super Loop */
}

void Timer_2_Init(void)
{
    /* Timer 2 is configured as a 16-bit timer,
       which is automatically reloaded when it overflows
       With these setting, timer will overflow every 1 ms */
    T2CON = 0x04; /* Load T2 control register */
    T2MOD = 0x00; /* Load T2 mode register */

    TH2 = 0xFC; /* Load T2 high byte */
    RCAP2H = 0xFC; /* Load T2 reload capt. reg. high byte */
    TL2 = 0x18; /* Load T2 low byte */
    RCAP2L = 0x18; /* Load T2 reload capt. reg. low byte */

    /* Timer 2 interrupt is enabled, and ISR will be called
       whenever the timer overflows - see below. */
    ET2 = 1;

    /* Start Timer 2 running */
    TR2 = 1;
}

void X(void) interrupt INTERRUPT_Timer_2_Overflow
{
    /* This ISR is called every 1 ms */
    /* Place required code here... */
}
```



---

## Overview of this seminar

This seminar will consider the design of a very flexible scheduler.

### THE CO-OPERATIVE SCHEDULER

- A co-operative scheduler provides a **single-tasking system** architecture

#### Operation:

- Tasks are scheduled to run at specific times (either on a one-shot or regular basis)
- When a task is scheduled to run it is added to the waiting list
- When the CPU is free, the next waiting task (if any) is executed
- The task runs to completion, then returns control to the scheduler

#### Implementation:

- The scheduler is simple, and can be implemented in a small amount of code.
- The scheduler must allocate memory for only a single task at a time.
- The scheduler will generally be written entirely in a high-level language (such as 'C').
- The scheduler is not a separate application; it becomes part of the developer's code

#### Performance:

- Obtain rapid responses to external events requires care at the design stage.

#### Reliability and safety:

- Co-operate scheduling is simple, predictable, reliable and safe.



---

## The Co-operative Scheduler

A scheduler has the following key components:

- The scheduler data structure.
- An initialisation function.
- A single interrupt service routine (ISR), used to update the scheduler at regular time intervals.
- A function for adding tasks to the scheduler.
- A dispatcher function that causes tasks to be executed when they are due to run.
- A function for removing tasks from the scheduler (not required in all applications).

We will consider each of the required components in turn.

---

## Overview

```
/*-----*/
void main(void)
{
    /* Set up the scheduler */
    SCH_Init_T2();

    /* Prepare for the 'Flash_LED' task */
    LED_Flash_Init();

    /* Add the 'Flash LED' task (on for ~1000 ms, off for ~1000 ms)
       Timings are in ticks (1 ms tick interval)
       (Max interval / delay is 65535 ticks) */
    SCH_Add_Task(LED_Flash_Update, 0, 1000);

    /* Start the scheduler */
    SCH_Start();

    while(1)
    {
        SCH_Dispatch_Tasks();
    }
}

/*-----*/
void SCH_Update(void) interrupt INTERRUPT_Timer_2_Overflow
{
    /* Update the task list */
    ...
}
```

---

## The scheduler data structure and task array

```
/* Store in DATA area, if possible, for rapid access
   Total memory per task is 7 bytes */
typedef data struct
{
  /* Pointer to the task (must be a 'void (void)' function) */
  void (code * pTask)(void);

  /* Delay (ticks) until the function will (next) be run
     - see SCH_Add_Task() for further details */
  tWord Delay;

  /* Interval (ticks) between subsequent runs.
     - see SCH_Add_Task() for further details */
  tWord Repeat;

  /* Incremented (by scheduler) when task is due to execute */
  tByte RunMe;
} sTask;
```

File Sch51.H also includes the constant SCH\_MAX\_TASKS:

```
/* The maximum number of tasks required at any one time
   during the execution of the program

   MUST BE ADJUSTED FOR EACH NEW PROJECT */
#define SCH_MAX_TASKS    (1)
```

Both the sTask data type and the SCH\_MAX\_TASKS constant are used to create - in the file Sch51.C - the array of tasks that is referred to throughout the scheduler:

```
/* The array of tasks */
sTask SCH_tasks_G[SCH_MAX_TASKS];
```

---

## The size of the task array

You **must** ensure that the task array is sufficiently large to store the tasks required in your application, by adjusting the value of `SCH_MAX_TASKS`.

For example, if you schedule three tasks as follows:

```
SCH_Add_Task(Function_A, 0, 2);  
SCH_Add_Task(Function_B, 1, 10);  
SCH_Add_Task(Function_C, 3, 15);
```

...then `SCH_MAX_TASKS` must have a value of 3 (or more) for correct operation of the scheduler.

Note also that - if this condition is not satisfied, the scheduler will generate an error code (more on this later).

---

## One possible initialisation function:

```
/*-----*/

void SCH_Init_T2(void)
{
    tByte i;

    for (i = 0; i < SCH_MAX_TASKS; i++)
    {
        SCH_Delete_Task(i);
    }

    /* SCH_Delete_Task() will generate an error code,
       because the task array is empty.
       -> reset the global error variable. */
    Error_code_G = 0;

    /* Now set up Timer 2
       16-bit timer function with automatic reload

       Crystal is assumed to be 12 MHz
       The Timer 2 resolution is 0.000001 seconds (1 µs)
       The required Timer 2 overflow is 0.001 seconds (1 ms)
       - this takes 1000 timer ticks
       Reload value is 65536 - 1000 = 64536 (dec) = 0xFC18 */

    T2CON = 0x04;    /* Load Timer 2 control register */
    T2MOD = 0x00;    /* Load Timer 2 mode register */

    TH2     = 0xFC;  /* Load Timer 2 high byte */
    RCAP2H  = 0xFC;  /* Load Timer 2 reload capture reg, high byte */
    TL2     = 0x18;  /* Load Timer 2 low byte */
    RCAP2L  = 0x18;  /* Load Timer 2 reload capture reg, low byte */

    ET2     = 1;    /* Timer 2 interrupt is enabled */

    TR2     = 1;    /* Start Timer 2 */
}

```

---

## **IMPORTANT:**

### **The ‘one interrupt per microcontroller’ rule!**

The scheduler initialisation function enables the generation of interrupts associated with the overflow of one of the microcontroller timers.

**For reasons discussed in Chapter 1 of PTTES, it is assumed throughout this course that only the ‘tick’ interrupt source is active: specifically, it is assumed that no other interrupts are enabled.**

If you attempt to use the scheduler code with additional interrupts enabled, **the system cannot be guaranteed to operate at all**: at best, you will generally obtain very unpredictable - and unreliable - system behaviour.

---

## The 'Update' function

```
/*-----*/
void SCH_Update(void) interrupt INTERRUPT_Timer_2_Overflow
{
    tByte Index;

    TF2 = 0; /* Have to manually clear this. */

    /* NOTE: calculations are in *TICKS* (not milliseconds) */
    for (Index = 0; Index < SCH_MAX_TASKS; Index++)
    {
        /* Check if there is a task at this location */
        if (SCH_tasks_G[Index].pTask)
        {
            if (--SCH_tasks_G[Index].Delay == 0)
            {
                /* The task is due to run */
                SCH_tasks_G[Index].RunMe += 1; /* Inc. 'RunMe' flag */

                if (SCH_tasks_G[Index].Period)
                {
                    /* Schedule regular tasks to run again */
                    SCH_tasks_G[Index].Delay = SCH_tasks_G[Index].Period;
                }
            }
        }
    }
}
```

---

## The 'Add Task' function

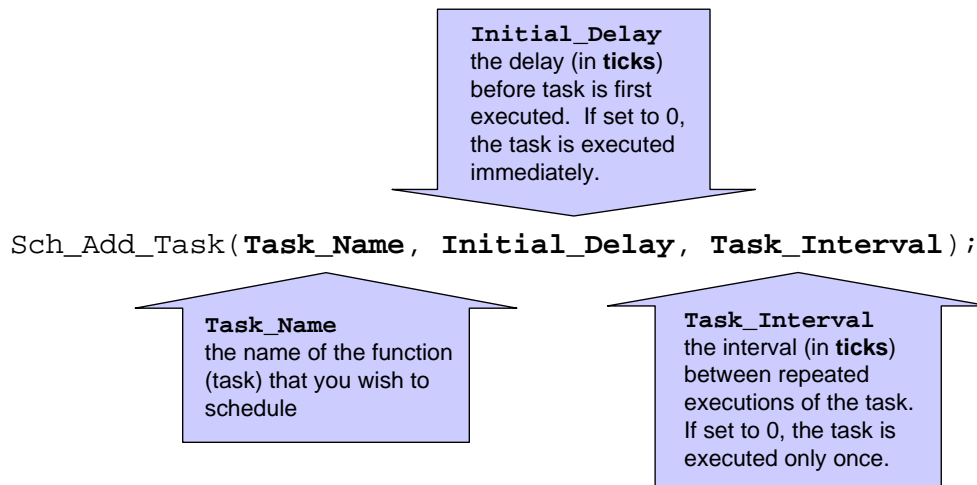

### Examples:

```
SCH_Add_Task(Do_X,1000,0);
```

```
Task_ID = SCH_Add_Task(Do_X,1000,0);
```

```
SCH_Add_Task(Do_X,0,1000);
```

This causes the function `Do_X( )` to be executed regularly, every 1000 scheduler ticks; task will be first executed at  $T = 300$  ticks, then 1300, 2300, etc:

```
SCH_Add_Task(Do_X,300,1000);
```



---

```

/*-----*/

SCH_Add_Task()

Causes a task (function) to be executed at regular
intervals, or after a user-defined delay.

-----*/
tByte SCH_Add_Task(void (code * pFunction>(),
                  const tWord DELAY,
                  const tWord PERIOD)
{
    tByte Index = 0;

    /* First find a gap in the array (if there is one) */
    while ((SCH_tasks_G[Index].pTask != 0) && (Index < SCH_MAX_TASKS))
    {
        Index++;
    }

    /* Have we reached the end of the list? */
    if (Index == SCH_MAX_TASKS)
    {
        /* Task list is full
           -> set the global error variable */
        Error_code_G = ERROR_SCH_TOO_MANY_TASKS;

        /* Also return an error code */
        return SCH_MAX_TASKS;
    }

    /* If we're here, there is a space in the task array */
    SCH_tasks_G[Index].pTask = pFunction;

    SCH_tasks_G[Index].Delay = DELAY + 1;
    SCH_tasks_G[Index].Period = PERIOD;

    SCH_tasks_G[Index].RunMe = 0;

    return Index; /* return pos. of task (to allow deletion) */
}

```

---

## The 'Dispatcher'

```
/*-----*/

SCH_Dispatch_Tasks()

This is the 'dispatcher' function. When a task (function)
is due to run, SCH_Dispatch_Tasks() will run it.
This function must be called (repeatedly) from the main loop.

-----*/
void SCH_Dispatch_Tasks(void)
{
    tByte Index;

    /* Dispatches (runs) the next task (if one is ready) */
    for (Index = 0; Index < SCH_MAX_TASKS; Index++)
    {
        if (SCH_tasks_G[Index].RunMe > 0)
        {
            (*SCH_tasks_G[Index].pTask)(); /* Run the task */

            SCH_tasks_G[Index].RunMe -= 1; /* Reduce RunMe count */

            /* Periodic tasks will automatically run again
             - if this is a 'one shot' task, delete it */
            if (SCH_tasks_G[Index].Period == 0)
            {
                SCH_Delete_Task(Index);
            }
        }
    }

    /* Report system status */
    SCH_Report_Status();

    /* The scheduler enters idle mode at this point */
    SCH_Go_To_Sleep();
}
```

---

The dispatcher is the only component in the Super Loop:

```
/* ----- */  
void main(void)  
{  
  
    ...  
  
    while(1)  
    {  
        SCH_Dispatch_Tasks();  
    }  
}
```

---

## Function arguments

- On desktop systems, function arguments are generally passed on the stack using the push and pop assembly instructions.
- Since the 8051 has a size limited stack (only 128 bytes at best and as low as 64 bytes on some devices), function arguments must be passed using a different technique.
- In the case of Keil C51, these arguments are stored in fixed memory locations.
- When the linker is invoked, it builds a call tree of the program, decides which function arguments are mutually exclusive (that is, which functions cannot be called at the same time), and overlays these arguments.

---

## Function pointers and Keil linker options

When we write:

```
SCH_Add_Task(Do_X,1000,0);
```

...the first parameter of the 'Add Task' function is a *pointer* to the function Do\_X( ).

This function pointer is then passed to the Dispatch function and it is through this function that the task is executed:

```
if (SCH_tasks_G[Index].RunMe > 0)
{
    (*SCH_tasks_G[Index].pTask)(); /* Run the task */
}
```

### BUT

The linker has difficulty determining the correct call tree when function pointers are used as arguments.

---

To deal with this situation, you have two realistic options:

1. You can prevent the compiler from using the OVERLAY directive by disabling overlays as part of the linker options for your project.

Note that, compared to applications using overlays, you will generally require more RAM to run your program.

2. You can tell the linker how to create the correct call tree for your application by explicitly providing this information in the linker ‘Additional Options’ dialogue box.

**This approach is used in most of the examples in the ‘PTTES’ book.**

```

void main(void)
{
    ...

    /* Read the ADC regularly */
    SCH_Add_Task(AD_Get_Sample, 10, 1000);

    /* Simply display the count here (bargraph display) */
    SCH_Add_Task(BARGRAPH_Update, 12, 1000);

    /* All tasks added: start running the scheduler */
    SCH_Start();
}

```

The corresponding OVERLAY directive would take this form:

```

OVERLAY (main ~ (AD_Get_Sample,Bargraph_Update),
sch_dispatch_tasks ! (AD_Get_Sample,Bargraph_Update))

```

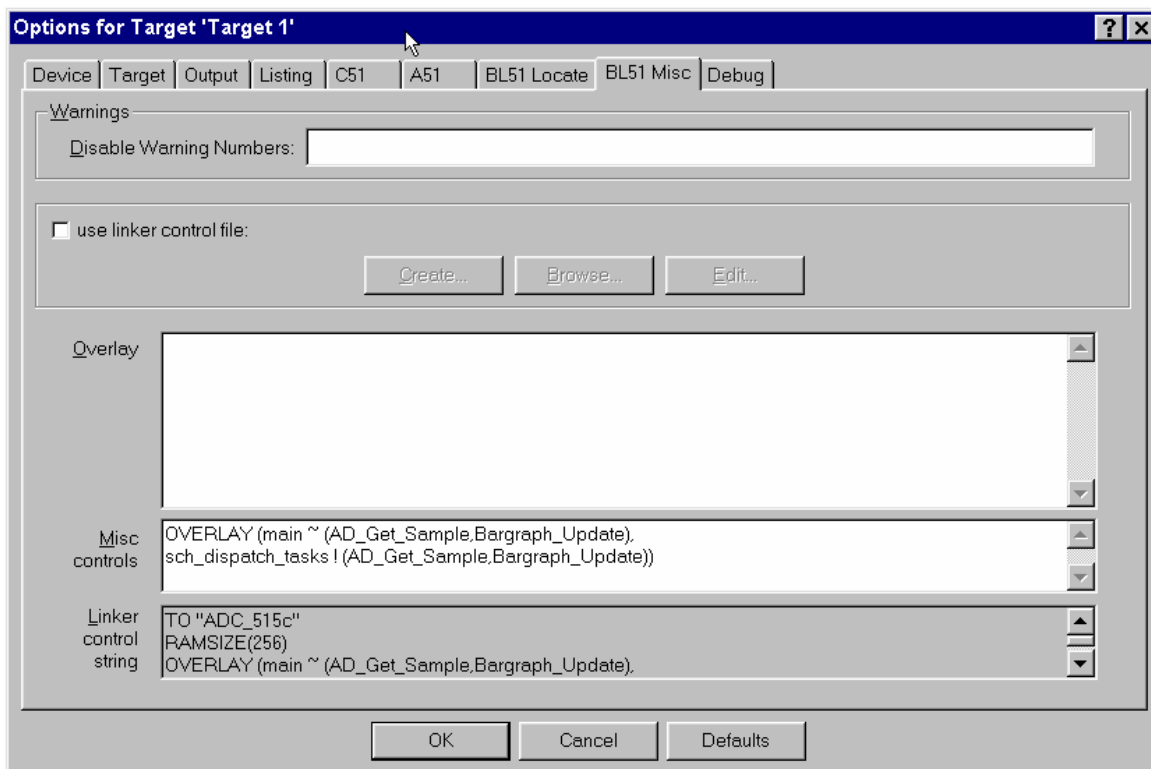

---

## The 'Start' function

```
/*-----*/
```

```
void SCH_Start(void)
{
    EA = 1;
}
```

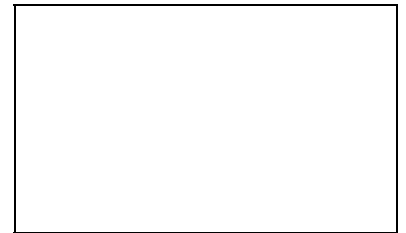



---

## The 'Delete Task' function

When tasks are added to the task array, SCH\_Add\_Task( ) returns the position in the task array at which the task has been added:

```
Task_ID = SCH_Add_Task(Do_X,1000,0);
```

Sometimes it can be necessary to delete tasks from the array.

You can do so as follows: SCH\_Delete\_Task(Task\_ID) ;

```
bit SCH_Delete_Task(const tByte TASK_INDEX)
{
    bit Return_code;

    if (SCH_tasks_G[TASK_INDEX].pTask == 0)
    {
        /* No task at this location...
           -> set the global error variable */
        Error_code_G = ERROR_SCH_CANNOT_DELETE_TASK;

        /* ...also return an error code */
        Return_code = RETURN_ERROR;
    }
    else
    {
        Return_code = RETURN_NORMAL;
    }

    SCH_tasks_G[TASK_INDEX].pTask    = 0x0000;
    SCH_tasks_G[TASK_INDEX].Delay    = 0;
    SCH_tasks_G[TASK_INDEX].Period   = 0;

    SCH_tasks_G[TASK_INDEX].RunMe    = 0;

    return Return_code;          /* return status */
}
```

---

## Reducing power consumption

```
/*-----*/  
void SCH_Go_To_Sleep()  
{  
    PCON |= 0x01;    /* Enter idle mode (generic 8051 version) */  
  
    /* Entering idle mode requires TWO consecutive instructions  
       on 80c515 / 80c505 - to avoid accidental triggering.  
       E.g:  
       PCON |= 0x01;  
       PCON |= 0x20; */  
}
```

---

## Reporting errors

```
/* Used to display the error code */  
tByte Error_code_G = 0;
```

To record an error we include lines such as:

```
Error_code_G = ERROR_SCH_TOO_MANY_TASKS;  
Error_code_G = ERROR_SCH_WAITING_FOR_SLAVE_TO_ACK;  
Error_code_G = ERROR_SCH_WAITING_FOR_START_COMMAND_FROM_MASTER;  
Error_code_G = ERROR_SCH_ONE_OR_MORE_SLAVES_DID_NOT_START;  
Error_code_G = ERROR_SCH_LOST_SLAVE;  
Error_code_G = ERROR_SCH_CAN_BUS_ERROR;  
Error_code_G = ERROR_I2C_WRITE_BYTE_AT24C64;
```

To report these error code, the scheduler has a function `SCH_Report_Status()`, which is called from the Update function.

---

```
/*-----*/
```

```
void SCH_Report_Status(void)
{
#ifdef SCH_REPORT_ERRORS
    /* ONLY APPLIES IF WE ARE REPORTING ERRORS */

    /* Check for a new error code */
    if (Error_code_G != Last_error_code_G)
    {
        /* Negative logic on LEDs assumed */
        Error_port = 255 - Error_code_G;

        Last_error_code_G = Error_code_G;

        if (Error_code_G != 0)
        {
            Error_tick_count_G = 60000;
        }
        else
        {
            Error_tick_count_G = 0;
        }
    }
    else
    {
        if (Error_tick_count_G != 0)
        {
            if (--Error_tick_count_G == 0)
            {
                Error_code_G = 0; /* Reset error code */
            }
        }
    }
}
#endif
}
```



---

Note that error reporting may be disabled via the `Port.H` header file:

```
/* Comment next line out if error reporting is NOT required */  
/* #define SCH_REPORT_ERRORS */
```

Where error reporting is required, the port on which error codes will be displayed is also determined via `Port.H`:

```
#ifndef SCH_REPORT_ERRORS  
/* The port on which error codes will be displayed  
(ONLY USED IF ERRORS ARE REPORTED) */  
#define Error_port P1  
  
#endif
```

Note that, in this implementation, error codes are reported for 60,000 ticks (1 minute at a 1 ms tick rate).

## Displaying error codes

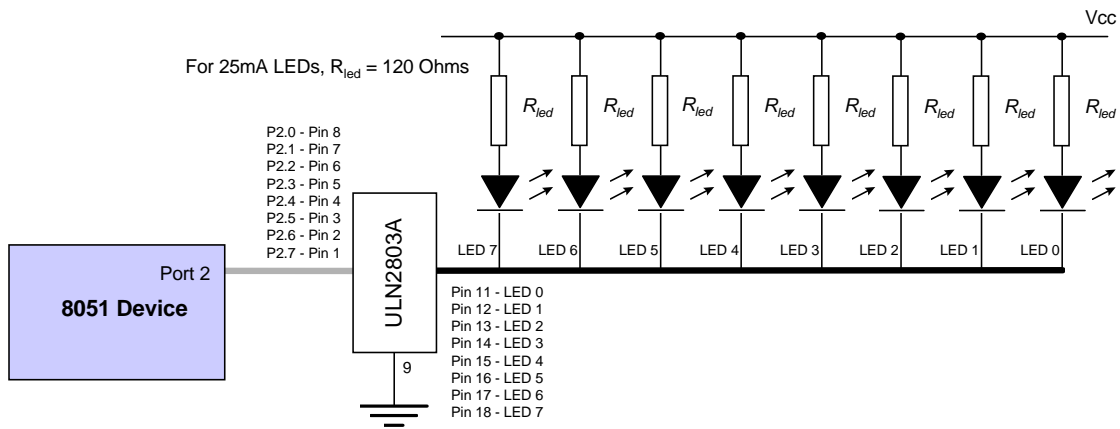

The forms of error reporting discussed here are low-level in nature and are primarily intended to assist the developer of the application, or a qualified service engineer performing system maintenance.

An additional user interface may also be required in your application to notify the user of errors, in a more user-friendly manner.

---

## Hardware resource implications

### Timer

The scheduler requires one hardware timer. If possible, this should be a 16-bit timer, with auto-reload capabilities (usually Timer 2).

### Memory

This main scheduler memory requirement is 7 bytes of memory per task.

Most applications require around six tasks or less. Even in a standard 8051/8052 with 256 bytes of internal memory the total memory overhead is small.

---

## What is the CPU load of the scheduler?

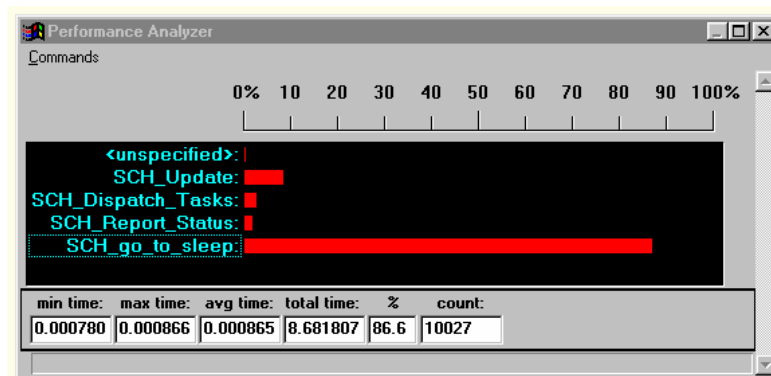

- A scheduler with 1ms ticks
- 12 Mhz, 12 osc / instruction 8051
- **One task is being executed.**
- The test reveals that the CPU is 86% idle and that the maximum possible task duration is therefore approximately 0.86 ms.



---

A scheduler with 1ms ticks,  
running on a **32 Mhz (4 oscillations per instruction) 8051**.

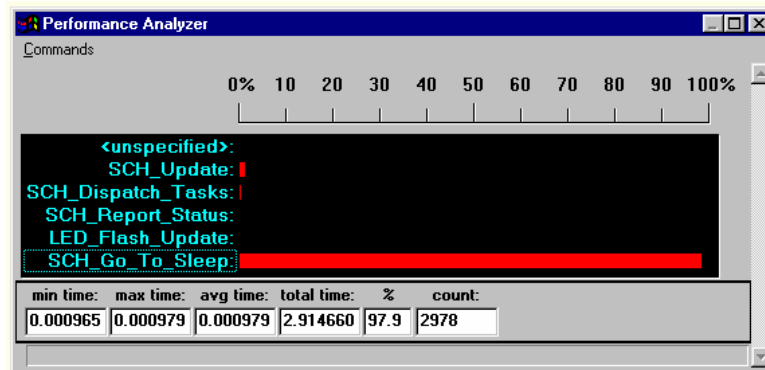

- **One task is being executed.**
- The CPU is 97% idle and that the maximum possible task duration is therefore approximately 0.97 ms.

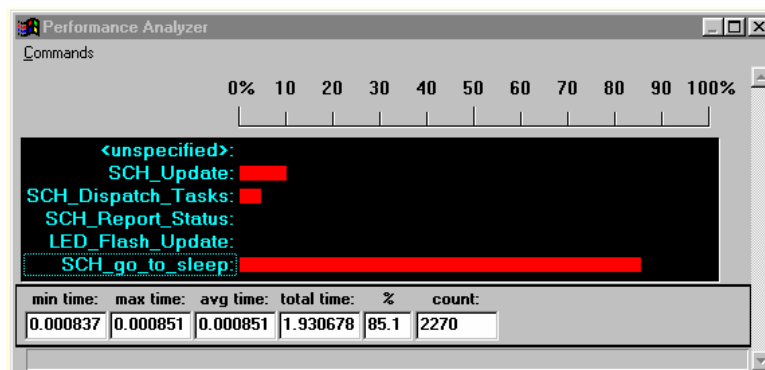

- **Twelve tasks are being executed.**
- The CPU is 85% idle and that the maximum possible task duration is therefore approximately 0.85 ms.

---

## Determining the required tick interval

In most instances, the simplest way of meeting the needs of the various task intervals is to allocate a scheduler tick interval of 1 ms.

To keep the scheduler load as low as possible (and to reduce the power consumption), it can help to use a **long tick interval**.

If you want to reduce overheads and power consumption to a minimum, the scheduler tick interval should be set to match the '**greatest common factor**' of all the task (and offset intervals).

---

Suppose we have three tasks (X,Y,Z), and Task X is to be run every 10 ms, Task Y every 30 ms and Task Z every 25 ms. The scheduler tick interval needs to be set by determining the relevant factors, as follows:

- The factors of the Task X interval (10 ms) are: 1 ms, 2ms, 5 ms, 10 ms.
- Similarly, the factors of the Task Y interval (30 ms) are as follows: 1 ms, 2 ms, 3 ms, 5 ms, 6 ms, 10 ms, 15 ms and 30 ms.
- Finally, the factors of the Task Z interval (25 ms) are as follows: 1 ms, 5 ms and 25 ms.

In this case, therefore, the greatest common factor is 5 ms: this is the required tick interval.

---

## Guidelines for predictable and reliable scheduling

1. For precise scheduling, the scheduler tick interval should be set to match the ‘greatest common factor’ of all the task intervals.
2. All tasks should have a duration less than the schedule tick interval, to ensure that the dispatcher is always free to call any task that is due to execute. Software simulation can often be used to measure the task duration.
3. In order to meet Condition 2, all tasks **must** ‘timeout’ so that they cannot block the scheduler under any circumstances.
4. The total time required to execute all of the scheduled tasks must be less than the available processor time. Of course, the total processor time must include both this ‘task time’ and the ‘scheduler time’ required to execute the scheduler update and dispatcher operations.
5. Tasks should be scheduled so that they are never required to execute simultaneously: that is, task overlaps should be minimised. Note that where **all** tasks are of a duration much less than the scheduler tick interval, and that some task jitter can be tolerated, this problem may not be significant.

---

## Overall strengths and weaknesses of the scheduler

- ☺ **The scheduler is simple, and can be implemented in a small amount of code.**
- ☺ **The scheduler is written entirely in 'C': it is not a separate application, but becomes part of the developer's code**
- ☺ **The applications based on the scheduler are inherently predictable, safe and reliable.**
- ☺ **The scheduler supports team working, since individual tasks can often be developed largely independently and then assembled into the final system.**
  
- ☹ Obtain rapid responses to external events requires care at the design stage.
- ☹ The tasks cannot safely use interrupts: the only interrupt that should be used in the application is the timer-related interrupt that drives the scheduler itself.

---

## Preparations for the next seminar

Please read “PTTES” Chapter 32 before the next seminar.

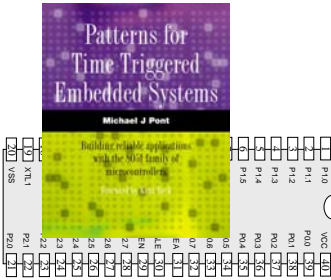

---

# Seminar 3:

## Analogue I/O using ADCs and PWM

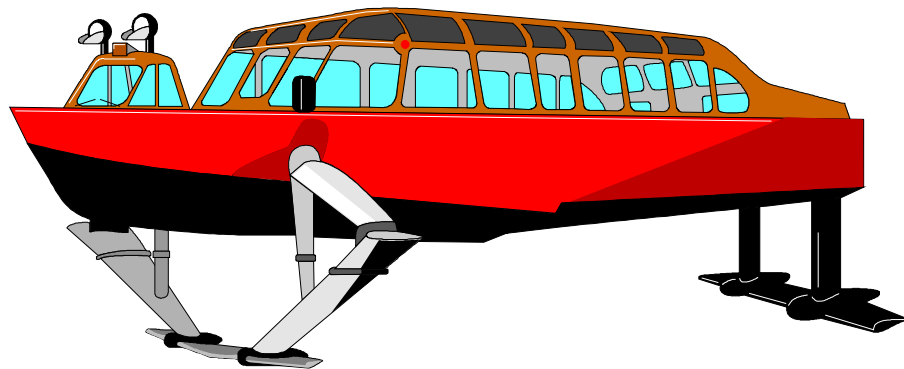
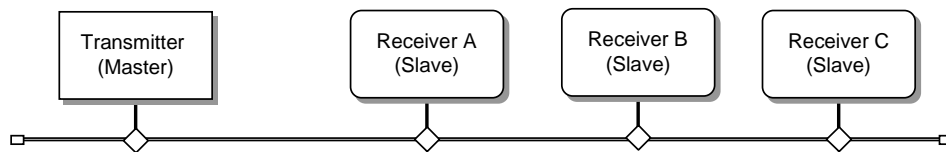

---

## Overview of this seminar

In this seminar, we will begin to consider how to make measurements of analogue voltages using a microcontroller.

We'll also consider how PWM can be used to generate analogue voltage values.



---

## PATTERN: One-Shot ADC<sup>1</sup>

In **ONE-SHOT ADC**, we are concerned with the use of analogue signals to address questions such as:

- What central-heating temperature does the user require?
- What is the current angle of the crane?
- What is the humidity level in Greenhouse 3?

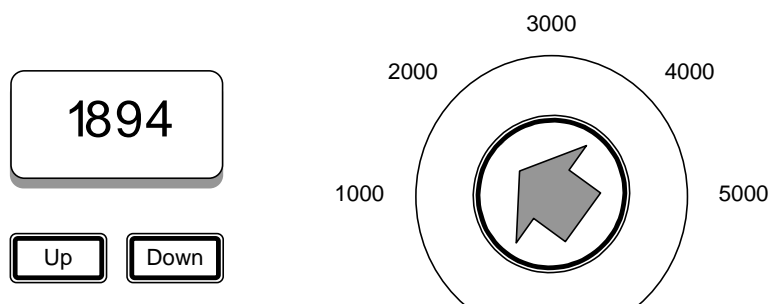
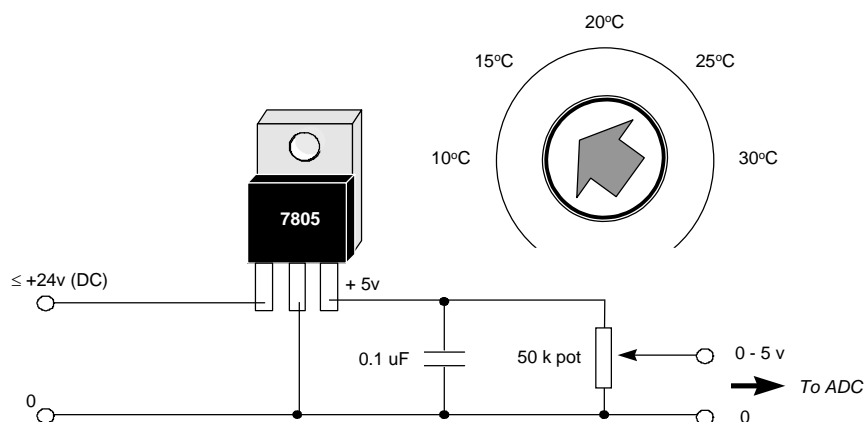

---

<sup>1</sup> See PTES p.757.

---

## **PATTERN: One-Shot ADC**

We begin by considering some of the hardware options that are available to allow the measurement of analogue voltage signals using a microcontroller.

Specifically, we will consider four options:

- Using a microcontroller with on-chip ADC;
- Using an external serial ADC;
- Using an external parallel ADC;
- Using a current-mode ADC.

---

## Using a microcontroller with on-chip ADC

Many members of the 8051 family contain on-board ADCs.

In general, use of an internal ADC (rather than an external one) will result in increased reliability, since both hardware and software complexity will generally be lower.

In addition, the ‘internal’ solution will usually be physically smaller, and have a lower system cost.

---

## Using an external parallel ADC

The ‘traditional’ alternative to an on-chip ADC is a parallel ADC. In general, parallel ADCs have the following strengths and weaknesses:

- ☺ **They can provide fast data transfers**
- ☺ **They tend to be inexpensive**
- ☺ **They require a very simple software framework**
- ☹ They tend to require a large number of port pins. In the case of a 16-bit conversion, the external ADC will require 16 pins for the data transfer, plus between 1 and 3 pins to control the data transfers.
- ☹ The wiring complexity can be a source of reliability problems in some environments.

We give examples of the use of a parallel ADC below.

---

## Example: Using a Max150 ADC

This example illustrates this use of an 8-bit parallel ADC: the Maxim MAX 150:

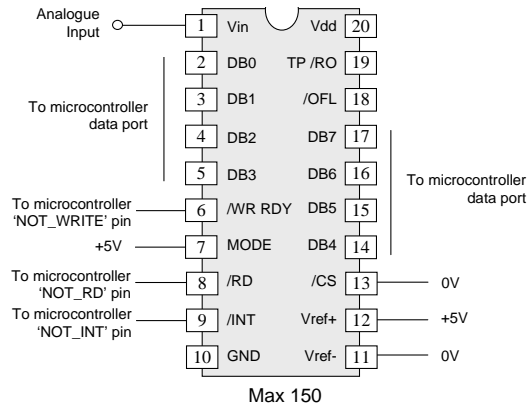

---

```

void ADC_Max150_Get_Sample(void)
{
    tWord Time_out_loop = 1;

    // Start conversion by pulling 'NOT Write' low
    ADC_Max150_NOT_Write_pin = 0;

    // Take sample from A-D (with simple loop time-out)
    while ((ADC_Max150_NOT_Int_pin == 1) && (Time_out_loop != 0));
    {
        Time_out_loop++; // Disable for use in dScope...
    }

    if (!Time_out_loop)
    {
        // Timed out
        Error_code_G =
        Analog_G = 0;
    }
    else
    {
        // Set port to 'read' mode
        ADC_Max150_port = 0xFF;

        // Set 'NOT read' pin low
        ADC_Max150_NOT_Read_pin = 0;

        // ADC result is now available
        Analog_G = ADC_Max150_port;

        // Set 'NOT read' pin high
        ADC_Max150_NOT_Read_pin = 1;
    }

    // Pull 'NOT Write' high
    ADC_Max150_NOT_Write_pin = 1;
}

```

**See PTTES, Chapter 32, for complete code listing**

---

## Using an external serial ADC

Many more recent ADCs have a serial interface. In general, serial ADCs have the following strengths and weaknesses:

- ☺ **They require a small number of port pins (between 2 and 4), regardless of the ADC resolution.**
- ☹ They require on-chip support for the serial protocol, or the use of a suitable software library.
- ☹ The data transfer may be slower than a parallel alternative.
- ☹ They can be comparatively expensive.

We give two examples of the use of serial ADCs below.

## Example: Using an external SPI ADC

This example illustrates the use of an external, serial (SPI) ADC (the SPI protocol is described in detail in PTTES, Chapter 24).

The hardware comprises an Atmel AT89S53 microcontroller, and a Maxim MAX1110 ADC:

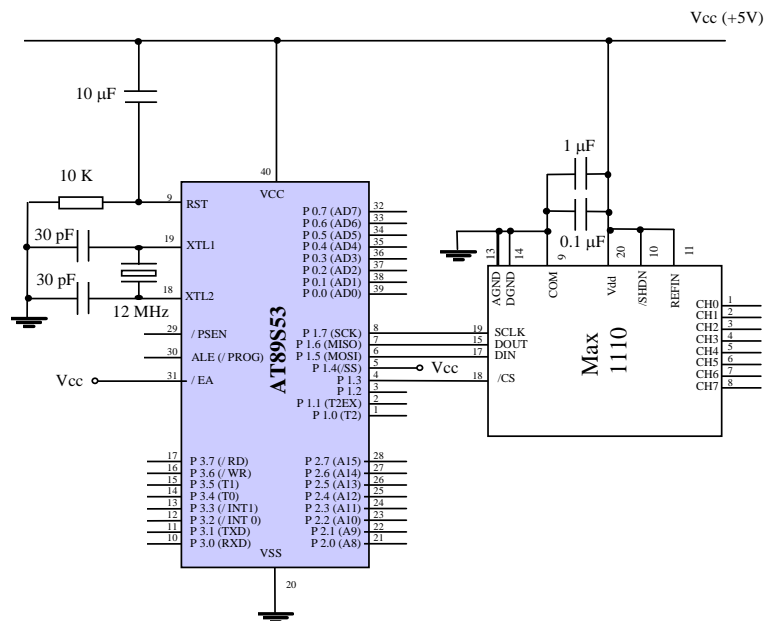

See **PTTES, Chapter 32**, for code



---

## Overview of SPI

There are five key features of SPI as far as the developer of embedded applications is concerned:

- SPI is a protocol designed to allow microcontrollers to be linked to a wide range of different peripherals - memory, displays, ADCs, and similar devices - and requires (typically) three port pins for the bus, plus one chip-select pin per peripheral.
- There are many SPI-compatible peripherals available for purchase ‘off the shelf’.
- Increasing numbers of ‘Standard’ and ‘Extended’ 8051 devices have hardware support for SPI.
- A common set of software code may be used with all SPI peripherals.
- SPI is compatible with time-triggered architectures and, as implemented in this course, is faster than I<sup>2</sup>C (largely due to the use of on-chip hardware support). Typical data transfer rates will be up to 5000 - 10000 bytes / second (with a 1-millisecond scheduler tick).

**See PTTES, Chapter 24, for SPI code libraries and more information about this protocol**

---

## Back to the example ...

```
tByte SPI_MAX1110_Read_Byte(void)
{
    tByte Data, Data0, Data1;

    // 0. Pin /CS is pulled low to select the device
    SPI_CS = 0;

    // 1. Send a MAX1110 control byte
    // Control byte 0x8F sets single-ended unipolar mode, channel 0 (pin 1)
    SPI_Exchange_Bytes(0x8F);

    // 2. The data requested is shifted out on SO by sending two dummy bytes
    Data0 = SPI_Exchange_Bytes(0x00);
    Data1 = SPI_Exchange_Bytes(0x00);

    // The data are contained in bits 5-0 of Data0
    // and 7-6 of Data1 - shift these bytes to give a combined byte,
    Data0 <<= 2;
    Data1 >>= 6;
    Data = (Data0 | Data1);

    // 3. We pull the /CS pin high to complete the operation
    SPI_CS = 1;

    // 4. We return the required data
    return Data; // Return SPI data byte
}
```

**See PTTES, Chapter 32, for complete code for this example**

---

## Example: Using an external I<sup>2</sup>C ADC

This example illustrates the use of an external, serial (I<sup>2</sup>C) ADC (the I<sup>2</sup>C protocol is described in detail in PTTES, Chapter 23).

The ADC hardware comprises a Maxim MAX127 ADC: this device is connected to the microcontroller as follows:

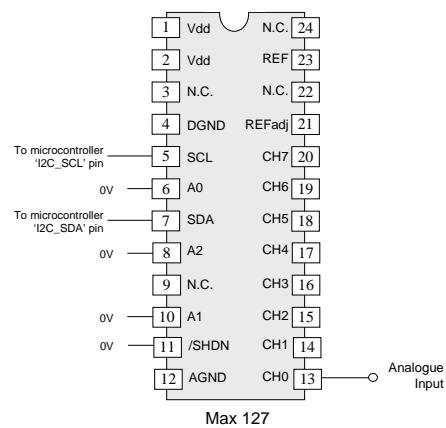

**See PTTES, Chapter 32, for code**

---

## Overview of I<sup>2</sup>C

There are five key features of I<sup>2</sup>C as far as the developer of embedded applications is concerned:

- I<sup>2</sup>C is a protocol designed to allow microcontrollers to be linked to a wide range of different peripherals - memory, displays, ADCs, and similar devices - and requires only two port pins to connect to (typically) up to twenty peripherals.
- There are many I<sup>2</sup>C peripherals available for purchase ‘off the shelf’.
- I<sup>2</sup>C is a simple protocol and may be easily generated in software. This allows all 8051 devices to communicate with a wide range of peripheral devices.
- A common set of software code may be used with all I<sup>2</sup>C peripherals.
- I<sup>2</sup>C is fast enough (even when generated in software) to be compatible with time-triggered architectures. Typical data transfer rates will be up to 1000 bytes / second (with a 1-millisecond scheduler tick).

**See PTTES, Chapter 23, for I2C code libraries and more information about this protocol**

---

## Back to the example ...

```
void I2C_ADC_Max127_Read(void)
{
    I2C_Send_Start(); // Generate I2C START condition

    // Send DAC device address (with write access request)
    if (I2C_Write_Byte(I2C_MAX127_ADDRESS | I2C_WRITE))
    {
        Error_code_G = ERROR_I2C_ADC_MAX127;
        return;
    }

    // Set the ADC mode and channel - see above
    if (I2C_Write_Byte(I2C_MAX127_MODE | I2C_MAX127_Channel_G))
    {
        Error_code_G = ERROR_I2C_ADC_MAX127;
        return;
    }

    I2C_Send_Stop(); // Generate STOP condition

    I2C_Send_Start(); // Generate START condition (again)

    // Send Max127 device address (with READ access request)
    if (I2C_Write_Byte(I2C_MAX127_ADDRESS | I2C_READ))
    {
        Error_code_G = ERROR_I2C_ADC_MAX127;
        return;
    }

    // Receive first (MS) byte from I2C bus
    ADC_G = I2C_Read_Byte();

    I2C_Send_Master_Ack(); // Perform a MASTER ACK

    // Here we require temperature only accurate to 1 degree C
    // - we discard LS byte (perform a dummy read)
    I2C_Read_Byte();

    I2C_Send_Master_NAck(); // Perform a MASTER NACK

    I2C_Send_Stop(); // Generate STOP condition
}
```

**See PTTES, Chapter 32, for complete code for this example**

---

## What is PWM?

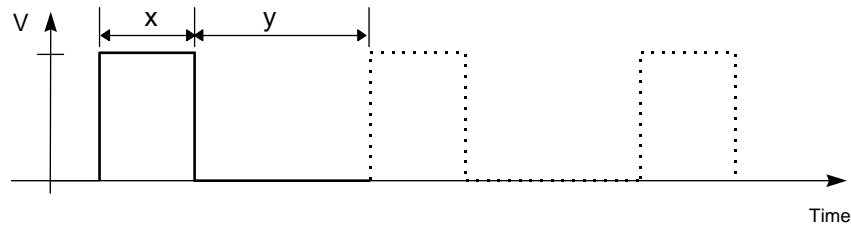

$$\text{Duty cycle (\%)} = \boxed{\phantom{000}}$$

Period =  $x + y$ , where  $x$  and  $y$  are in seconds.

$$\text{Frequency} = \boxed{\phantom{000}}, \text{ where } x \text{ and } y \text{ are in seconds.}$$

The key point to note is that the average voltage seen by the load is given by the duty cycle multiplied by the load voltage.

**See PTES, Chapter 33**

---

## PATTERN: Software PWM

```
void PWM_Soft_Update(void)
{
    // Have we reached the end of the current PWM cycle?
    if (++PWM_position_G >= PWM_PERIOD)
    {
        // Reset the PWM position counter
        PWM_position_G = 0;

        // Update the PWM control value
        PWM_G = PWM_new_G;

        // Set the PWM output to ON
        PWM_pin = PWM_ON;

        return;
    }

    // We are in a PWM cycle
    if (PWM_position_G < PWM_G)
    {
        PWM_pin = PWM_ON;
    }
    else
    {
        PWM_pin = PWM_OFF;
    }
}
```

**See PTTES, Chapter 33, for complete code for this example**

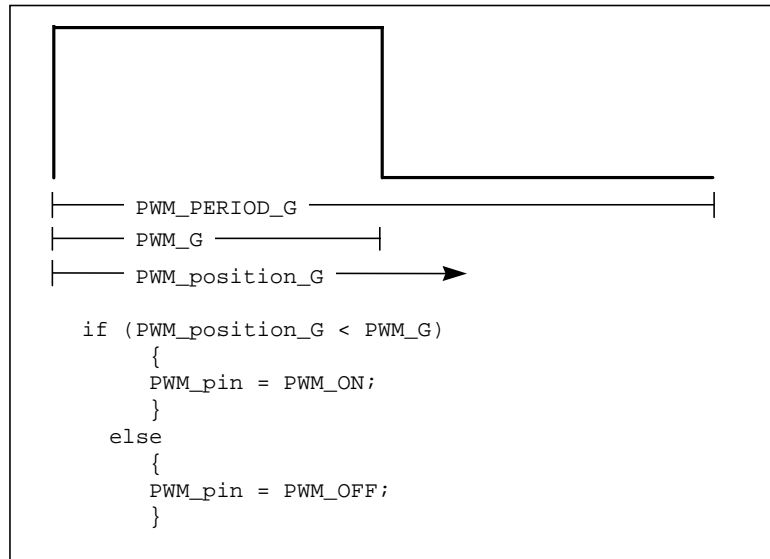

- PWM\_period\_G is the current PRM period. Note that if the update function is scheduled every millisecond, then this period is in milliseconds. PWM\_period\_G is fixed during the program execution.
- PWM\_G represents the current PWM duty cycle
- PWM\_new\_G is the next PWM duty cycle. This period may be varied by the user, as required. Note that the ‘new’ value is only copied to PWM\_G at the end of a PWM cycle, to avoid noise.
- PWM\_position\_G is the current position in the PWM cycle. This is incremented by the update function. Again, the units are milliseconds if the conditions above apply.



---

Using a 1 ms scheduler, the PWM frequency (Hz) and PWM resolution (%) we obtain are given by:

and,

$$Resolution_{PWM} \text{  \%}$$

where N is the number of PWM bits you use.

For example, 5-bit PWM allows you to control the output to a resolution of approximately 3%, at a frequency of approximately 31Hz.

---

## Preparations for the next seminar

Please read “PTTES” Chapter 17 (and skim read 36 and 37) before the next seminar.

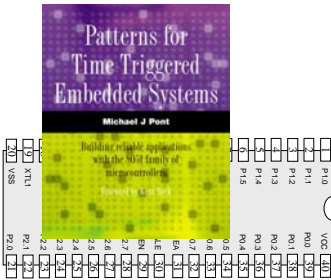

---

# Seminar 4:

## A closer look at co-operative task scheduling (and some alternatives)

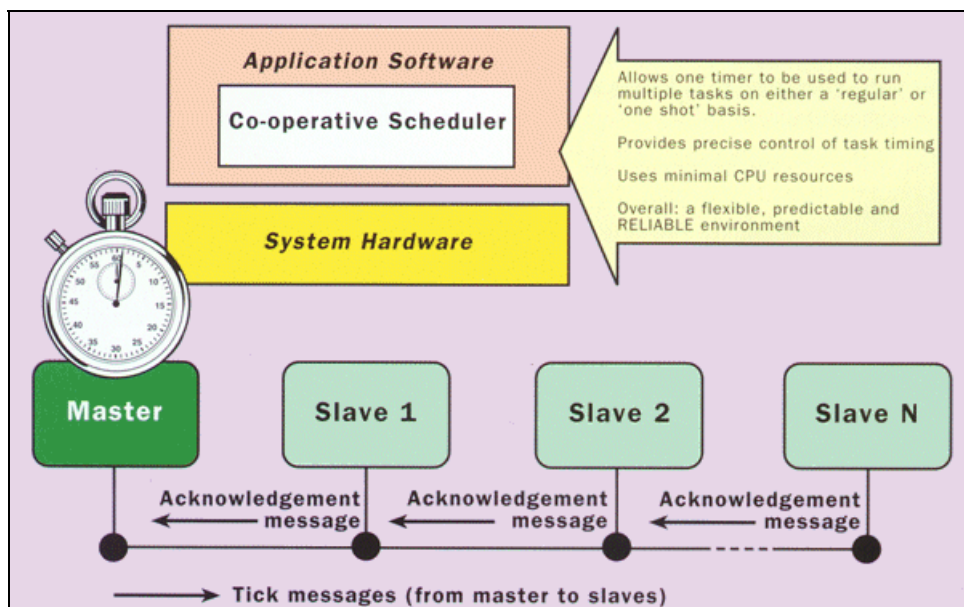

---

## Overview of this seminar

- In this seminar, we'll review some of the features of the co-operative scheduler discussed in seminars 1 and 2.
- We'll then consider the features of a pre-emptive scheduler
- We'll go on to develop a **hybrid scheduler**, which has many of the useful features of both co-operative and pre-emptive schedulers (but is simpler to build - and generally more reliable - than a fully pre-emptive design)
- Finally, we'll look at a range of different designs for other forms of (co-operative) scheduler.

---

## Review: Co-operative scheduling

### THE CO-OPERATIVE SCHEDULER

- A co-operative scheduler provides a **single-tasking system** architecture

#### Operation:

- Tasks are scheduled to run at specific times (either on a one-shot or regular basis)
- When a task is scheduled to run it is added to the waiting list
- When the CPU is free, the next waiting task (if any) is executed
- The task runs to completion, then returns control to the scheduler

#### Implementation:

- The scheduler is simple, and can be implemented in a small amount of code.
- The scheduler must allocate memory for only a single task at a time.
- The scheduler will generally be written entirely in a high-level language (such as 'C').
- The scheduler is not a separate application; it becomes part of the developer's code

#### Performance:

- Obtain rapid responses to external events requires care at the design stage.

#### Reliability and safety:

- Co-operate scheduling is simple, predictable, reliable and safe.

---

# The pre-emptive scheduler

## Overview:

### THE PRE-EMPTIVE SCHEDULER

- A pre-emptive scheduler provides a **multi-tasking system** architecture

#### Operation:

- Tasks are scheduled to run at specific times (either on a one-shot or regular basis)
- When a task is scheduled to run it is added to the waiting list
- Waiting tasks (if any) are run for a fixed period then - if not completed - are paused and placed back in the waiting list. The next waiting task is then run for a fixed period, and so on.

#### Implementation:

- The scheduler is comparatively complicated, not least because features such as semaphores must be implemented to avoid conflicts when 'concurrent' tasks attempt to access shared resources.
- The scheduler must allocate memory is to hold all the intermediate states of pre-empted tasks.
- The scheduler will generally be written (at least in part) in assembly language.
- The scheduler is generally created as a separate application.

#### Performance:

- Rapid responses to external events can be obtained.

#### Reliability and safety:

- Generally considered to be less predictable, and less reliable, than co-operative approaches.

---

## Why do we avoid pre-emptive schedulers in this course?

Various research studies have demonstrated that, compared to pre-emptive schedulers, co-operative schedulers have a number of desirable features, particularly for use in safety-related systems.

*“[Pre-emptive] schedules carry greater runtime overheads because of the need for context switching - storage and retrieval of partially computed results. [Co-operative] algorithms do not incur such overheads. Other advantages of [co-operative] algorithms include their better understandability, greater predictability, ease of testing and their inherent capability for guaranteeing exclusive access to any shared resource or data.”.*

Nissanke (1997, p.237)

*“Significant advantages are obtained when using this [co-operative] technique. Since the processes are not interruptable, poor synchronisation does not give rise to the problem of shared data. Shared subroutines can be implemented without producing re-entrant code or implementing lock and unlock mechanisms”.*

Allworth (1981, p.53-54)

Compared to pre-emptive alternatives, co-operative schedulers have the following advantages: [1] The scheduler is simpler; [2] The overheads are reduced; [3] Testing is easier; [4] Certification authorities tend to support this form of scheduling.

Bate (2000)

**[See PTTES, Chapter 13]**

---

## Why is a co-operative scheduler (generally) more reliable?

- The key reason why the co-operative schedulers are both reliable and predictable is that only one task is active at any point in time: this task runs to completion, and then returns control to the scheduler.
- Contrast this with the situation in a fully pre-emptive system with more than one active task.
- Suppose one task in such a system which is reading from a port, and the scheduler performs a 'context switch', causing a different task to access the same port: under these circumstances, unless we take action to prevent it, data may be lost or corrupted.

This problem arises frequently in multi-tasking environments where we have what are known as 'critical sections' of code.

Such critical sections are code areas that - once started - must be allowed to run to completion without interruption.



---

## Critical sections of code

Examples of critical sections include:

- Code which modifies or reads variables, particularly global variables used for inter-task communication. In general, this is the most common form of critical section, since inter-task communication is often a key requirement.
- Code which interfaces to hardware, such as ports, analogue-to-digital converters (ADCs), and so on. What happens, for example, if the same ADC is used simultaneously by more than one task?
- Code which calls common functions. What happens, for example, if the same function is called simultaneously by more than one task?

In a co-operative system, problems with critical sections do not arise, since only one task is ever active at the same time.

---

## How do we deal with critical sections in a pre-emptive system?

To deal with such critical sections of code in a pre-emptive system, we have two main possibilities:

- ‘Pause’ the scheduling by disabling the scheduler interrupt before beginning the critical section; re-enable the scheduler interrupt when we leave the critical section, or;
- Use a ‘lock’ (or some other form of ‘semaphore mechanism’) to achieve a similar result.

The first solution can be implemented as follows:

- When Task A (say) starts accessing the shared resource (say Port X), we disable the scheduler.
- This solves the immediate problem since Task A will be allowed to run without interruption until it has finished with Port X.
- However, this ‘solution’ is less than perfect. For one thing, by disabling the scheduler, we will no longer be keeping track of the elapsed time and all timing functions will begin to drift - in this case by a period up to the duration of Task A every time we access Port X. This is not acceptable in most applications.

---

## Building a “lock” mechanism

The use of locks is a better solution.

Before entering the critical section of code, we ‘lock’ the associated resource; when we have finished with the resource we ‘unlock’ it. While locked, no other process may enter the critical section.

This is one way we might try to achieve this:

1. Task A checks the ‘lock’ for Port X it wishes to access.
2. If the section is locked, Task A waits.
3. When the port is unlocked, Task A sets the lock and then uses the port.
4. When Task A has finished with the port, it leaves the critical section and unlocks the port.

---

## Implementing this algorithm in code also seems straightforward:

```
#define UNLOCKED 0
#define LOCKED 1

bit Lock; // Global lock flag

// ...

// Ready to enter critical section
// - Wait for lock to become clear
// (FOR SIMPLICITY, NO TIMEOUT CAPABILITY IS SHOWN)
while(Lock == LOCKED);

// Lock is clear
// Enter critical section

// Set the lock
Lock = LOCKED;

// CRITICAL CODE HERE //

// Ready to leave critical section
// Release the lock
Lock = UNLOCKED;

// ...
```

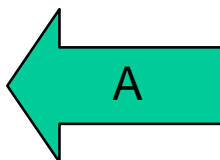

---

However, the above code cannot be guaranteed to work correctly under all circumstances.

Consider the part of the code labelled 'A'. If our system is fully pre-emptive, then our task can reach this point at the same time as the scheduler performs a context switch and allows (say) Task B access to the CPU. If Task Y also wants to access the Port X, we can then have a situation as follows:

- Task A has checked the lock for Port X and found that the port is available; Task A has, however, not yet changed the lock flag.
- Task B is then 'switched in'. Task B checks the lock flag and it is still clear. Task B sets the lock flag and begins to use Port X.
- Task A is 'switched in' again. As far as Task A is concerned, the port is not locked; this task therefore sets the flag, and starts to use the port, unaware that Task B is already doing so.
- ...

As we can see, this simple lock code violates the principal of mutual exclusion: that is, it allows more than one task to access a critical code section. The problem arises because it is possible for the context switch to occur after a task has checked the lock flag but before the task changes the lock flag. **In other words, the lock 'check and set code' (designed to control access to a critical section of code), is itself a critical section.**

- 
- This problem can be solved.
  - For example, because it takes little time to ‘check and set’ the lock code, we can disable interrupts for this period.
  - However, this is not in itself a complete solution: because there is a chance that an interrupt may have occurred even in the short period of ‘check and set’, we then need to check the relevant interrupt flag(s) and - if necessary - call the relevant ISR(s). This can be done, but it adds substantially to the complexity of the operating environment.

Even if we build a working lock mechanism, this is only a partial solution to the problems caused by multi-tasking. If the purpose of Task A is to read from an ADC, and Task B has locked the ADC when the Task A is invoked, then Task A cannot carry out its required activity. Use of locks (or any other mechanism), can prevent the system from crashing, but cannot allow two tasks to have access to the ADC simultaneously.

**When using a co-operative scheduler, such problems do not arise.**

---

## The “best of both worlds” - a hybrid scheduler

### THE HYBRID SCHEDULER

- A **hybrid scheduler** provides limited **multi-tasking** capabilities

#### Operation:

- Supports any number of co-operatively-scheduled tasks
- Supports a single pre-emptive task (which can interrupt the co-operative tasks)

#### Implementation:

- The scheduler is simple, and can be implemented in a small amount of code.
- The scheduler must allocate memory for - at most - **two tasks** at a time.
- The scheduler will generally be written entirely in a high-level language (such as 'C').
- The scheduler is not a separate application; it becomes part of the developer's code

#### Performance:

- Rapid responses to external events can be obtained.

#### Reliability and safety:

- With **careful design**, can be as reliable as a (pure) co-operative scheduler.

---

## Creating a hybrid scheduler

The ‘update’ function from a co-operative scheduler:

```
void SCH_Update(void) interrupt INTERRUPT_Timer_2_Overflow
{
    tByte Index;

    TF2 = 0; /* Have to manually clear this. */

    /* NOTE: calculations are in *TICKS* (not milliseconds) */
    for (Index = 0; Index < SCH_MAX_TASKS; Index++)
    {
        /* Check if there is a task at this location */
        if (SCH_tasks_G[Index].Task_p)
        {
            if (--SCH_tasks_G[Index].Delay == 0)
            {
                /* The task is due to run */
                SCH_tasks_G[Index].RunMe += 1; /* Inc. RunMe */

                if (SCH_tasks_G[Index].Period)
                {
                    /* Schedule periodic tasks to run again */
                    SCH_tasks_G[Index].Delay = SCH_tasks_G[Index].Period;
                }
            }
        }
    }
}
```



---

The co-operative version assumes a scheduler data type as follows:

```
/* Store in DATA area, if possible, for rapid access  
   [Total memory per task is 7 bytes] */  
typedef data struct  
{  
/* Pointer to the task (must be a 'void (void)' function) */  
void (code * Task_p)(void);  
  
/* Delay (ticks) until the function will (next) be run  
   - see SCH_Add_Task() for further details */  
tWord Delay;  
  
/* Interval (ticks) between subsequent runs.  
   - see SCH_Add_Task() for further details */  
tWord Period;  
  
/* Set to 1 (by scheduler) when task is due to execute */  
tByte RunMe;  
} sTask;
```

---

## The 'Update' function for a hybrid scheduler.

```
void hSCH_Update(void) interrupt INTERRUPT_Timer_2_Overflow
{
    tByte Index;

    TF2 = 0; /* Have to manually clear this. */

    /* NOTE: calculations are in *TICKS* (not milliseconds) */
    for (Index = 0; Index < hSCH_MAX_TASKS; Index++)
    {
        /* Check if there is a task at this location */
        if (hSCH_tasks_G[Index].pTask)
        {
            if (--hSCH_tasks_G[Index].Delay == 0)
            {
                /* The task is due to run */
                if (hSCH_tasks_G[Index].Co_op)
                {
                    /* If it is co-op, inc. RunMe */
                    hSCH_tasks_G[Index].RunMe += 1;
                }
            }
            else
            {
                /* If it is a pre-emp, run it IMMEDIATELY */
                (*hSCH_tasks_G[Index].pTask)();

                hSCH_tasks_G[Index].RunMe -= 1; /* Dec RunMe */

                /* Periodic tasks will automatically run again
                - if this is a 'one shot' task, delete it. */
                if (hSCH_tasks_G[Index].Period == 0)
                {
                    hSCH_tasks_G[Index].pTask = 0;
                }
            }

            if (hSCH_tasks_G[Index].Period)
            {
                /* Schedule regular tasks to run again */
                hSCH_tasks_G[Index].Delay = hSCH_tasks_G[Index].Period;
            }
        }
    }
}
```

---

The hybrid version assumes a scheduler data type as follows:

```
/* Store in DATA area, if possible, for rapid access  
   [Total memory per task is 8 bytes] */  
typedef data struct  
{  
  /* Pointer to the task (must be a 'void (void)' function) */  
  void (code * Task_p)(void);  
  
  /* Delay (ticks) until the function will (next) be run  
     - see SCH_Add_Task() for further details. */  
  tWord Delay;  
  
  /* Interval (ticks) between subsequent runs.  
     - see SCH_Add_Task() for further details. */  
  tWord Period;  
  
  /* Set to 1 (by scheduler) when task is due to execute */  
  tByte RunMe;  
  
  /* Set to 1 if task is co-operative;  
     Set to 0 if task is pre-emptive. */  
  tByte Co_op;  
} sTask;
```

---

**Initial\_Delay**  
the delay (in ticks)  
before task is first  
executed. If set to 0,  
the task is executed  
immediately.

`Sch_Add_Task(Task_Name, Initial_Delay, Period);`

**Task\_Name**  
the name of the function  
(task) that you wish to  
schedule

**Period**  
the interval (in ticks)  
between repeated  
executions of the task.  
If set to 0, the task is  
executed only once.

**Initial\_Delay**  
the delay (in ticks)  
before task is first  
executed. If set to 0,  
the task is executed  
immediately.

**Co\_op**  
set to '1' if the task is  
co-operative;  
set to '0' if the task is  
pre-emptive

`hSCH_Add_Task(Task_Name, Initial_Delay, Period, Co_op);`

**Task\_Name**  
the name of the function  
(task) that you wish to  
schedule

**Period**  
the interval (ticks)  
between repeated  
executions of the task.  
If set to 0, the task is  
executed only once.

---

## Reliability and safety issues

As we have seen, in order to deal with critical sections of code in a **fully pre-emptive system**, we have two main possibilities:

- ‘Pause’ the scheduling by disabling the scheduler interrupt before beginning the critical section; re-enable the scheduler interrupt when we leave the critical section, or;
- Use a ‘lock’ (or some other form of ‘semaphore mechanism’) to achieve a similar result.

Problems occur with the second solution if a task is interrupted after it reads the lock flag (and finds it unlocked) and before it sets the flag (to indicate that the resource is in use).

```
// ...  
  
// Ready to enter critical section  
// - Check lock is clear  
if (Lock == LOCKED)  
{  
    return;  
}  
  
// Lock is clear  
// Enter critical section  
  
// Set the lock  
Lock = LOCKED;  
  
// CRITICAL CODE HERE //
```

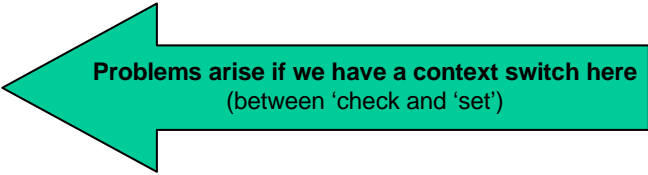

**Problems arise if we have a context switch here**  
(between 'check and 'set')

---

The problem does not occur in a hybrid scheduler, for the following reasons:

- In the case of pre-emptive tasks - because they cannot be interrupted - the ‘interrupt between check and lock’ situation cannot arise.
- In the case of co-operative tasks (which can be interrupted), the problem again cannot occur, for slightly different reasons.

Co-operative tasks can be interrupted ‘between check and lock’, but only by a pre-emptive task. If the pre-emptive task interrupts and finds that a critical section is unlocked, it will set the lock<sup>2</sup>, use the resource, then clear the lock: that is, it will run to completion. The co-operative task will then resume and will **find the system in the same state that it was in before the pre-emptive task interrupted**: as a result, there can be no breach of the mutual exclusion rule.

Note that the hybrid scheduler solves the problem of access to critical sections of code in a simple way: unlike the complete pre-emptive scheduler, we do not require the creation of complex code ‘lock’ or ‘semaphore’ structures.

---

<sup>2</sup> Strictly, setting the lock flag is not necessary, as no interruption is possible.

---

## The safest way to use the hybrid scheduler

The most reliable way to use the hybrid scheduler is as follows

- Create as many co-operative tasks as you require. It is likely that you will be using a hybrid scheduler because one or more of these tasks may have a duration greater than the tick interval; this can be done safely with a hybrid scheduler, but you **must** ensure that the tasks do not overlap.
- Implement **one** pre-emptive task; typically (but not necessarily) this will be called at every tick interval. A good use of this task is, for example, to check for errors or emergency conditions: this task can thereby be used to ensure that your system is able to respond within (say) 10ms to an external event, even if its main purpose is to run (say) a 1000 ms co-operative task.
- Remember that the pre-emptive task(s) can interrupt the co-operative tasks. If there are critical code sections, **you need to implement a simple lock mechanism**
- The pre-emptive task must be **short** (with a maximum duration of around 50% of the tick interval - preferably **much less**), otherwise overall system performance will be greatly impaired.
- Test the application carefully, under a full range of operating conditions, and monitor for errors.

---

## Overall strengths and weaknesses

The overall strengths and weaknesses of Hybrid Scheduler may be summarised as follows:

- ☺ **Has the ability to deal with both ‘long infrequent tasks’ and (a single) ‘short frequent task’ that cannot be provided by a pure Co-operative Scheduler.**
- ☺ **Is safe and predictable, if used according to the guidelines.**
- ☹ It must be handled with caution.



---

## Other forms of co-operative scheduler

- **255-TICK SCHEDULER** [PTTES, p.747]  
A scheduler designed to run multiple tasks, but with reduced memory (and CPU) overheads. This scheduler operates in the same way as the standard co-operative schedulers, but all information is stored in byte-sized (rather than word-sized) variables: this reduces the required memory for each task by around 30%.
- **ONE-TASK SCHEDULER** [PTTES, p.749]  
A stripped-down, co-operative scheduler able to manage a single task. This very simple scheduler makes very efficient use of hardware resources, with the bare minimum of CPU and memory overheads.
- **ONE-YEAR SCHEDULER** [PTTES, p.755]  
A scheduler designed for very low-power operation: specifically, it is designed to form the basis of battery-powered applications capable of operating for a year or more from a small, low-cost, battery supply.
- **STABLE SCHEDULER** [PTTES, p.932]  
is a temperature-compensated scheduler that adjusts its behaviour to take into account changes in ambient temperature.

---

## PATTERN: 255-TICK SCHEDULER

- A scheduler designed to run multiple tasks, but with reduced memory (and CPU) overheads. This scheduler operates in the same way as the standard co-operative schedulers, but all information is stored in byte-sized (rather than word-sized) variables: this reduces the required memory for each task by around 30%.

```
/* Store in DATA area, if possible, for rapid access  
   [Total memory per task is 5 bytes] */  
typedef data struct  
{  
  /* Pointer to the task (must be a 'void (void)' function) */  
  void (code * pTask)(void);  
  
  /* Delay (ticks) until the function will (next) be run  
     - see SCH_Add_Task() for further details. */  
  tByte Delay;  
  
  /* Interval (ticks) between subsequent runs.  
     - see SCH_Add_Task() for further details. */  
  tByte Period;  
  
  /* Incremented (by scheduler) when task is due to execute */  
  tByte RunMe;  
} sTask;
```

---

## PATTERN: ONE-TASK SCHEDULER

- A stripped-down, co-operative scheduler able to manage a single task. This very simple scheduler makes very efficient use of hardware resources, with the bare minimum of CPU and memory overheads.
- **Very similar in structure (and use) to “sEOS” (in PES I).**
- The scheduler will consume no significant CPU resources: short of implementing the application as a **SUPER LOOP** (with all the disadvantages of this rudimentary architecture), there is generally no more efficient way of implementing your application in a high-level language.
- **Allows 0.1 ms tick intervals - even on the most basic 8051.**

This approach can be both safe and reliable, provided that you do not attempt to ‘shoe-horn’ a multi-task design into this single-task framework.

---

## PATTERN: ONE-YEAR SCHEDULER

- A scheduler designed for very low-power operation: specifically, it is designed to form the basis of battery-powered applications capable of operating for a year or more from a small, low-cost, battery supply.
- AA cells are particularly popular, are widely available throughout the world, and are appropriate for many applications. The ubiquitous Duracell MN1500, for example, has a rating of 1850 mAh. At low currents (an average of around 0.3 mA), you can expect to get at least a year of life from such cells.
- To obtain such current consumption, choose a LOW operating frequency (e.g. watch crystal, 32 kHz)
- **NOTE: Performance will be limited!**

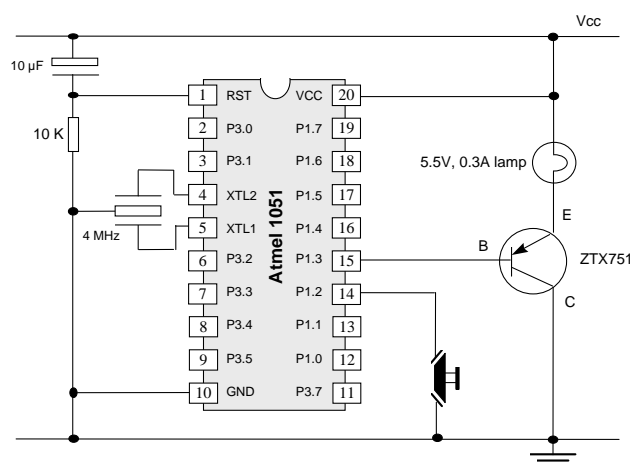

---

## PATTERN: STABLE SCHEDULER

- A temperature-compensated scheduler that adjusts its behaviour to take into account changes in ambient temperature.

```
/* The temperature compensation data
```

```
The Timer 2 reload values (low and high bytes) are varied depending  
on the current average temperature.
```

```
NOTE (1):
```

```
Only temperature values from 10 - 30 celsius are considered  
in this version
```

```
NOTE (2):
```

```
Adjust these values to match your hardware! */
```

```
tByte code T2_reload_L[21] =  
    /* 10 11 12 13 14 15 16 17 18 19 */  
    {0xBA,0xB9,0xB8,0xB7,0xB6,0xB5,0xB4,0xB3,0xB2,0xB1,  
    /* 20 21 22 23 24 25 26 27 28 29 30 */  
    0xB0,0xAF,0xAE,0xAD,0xAC,0xAB,0xAA,0xA9,0xA8,0xA7,0xA6};  
  
tByte code T2_reload_H[21] =  
    /* 10 11 12 13 14 15 16 17 18 19 */  
    {0x3C,0x3C,0x3C,0x3C,0x3C,0x3C,0x3C,0x3C,0x3C,0x3C,  
    /* 20 21 22 23 24 25 26 27 28 29 30 */  
    0x3C,0x3C,0x3C,0x3C,0x3C,0x3C,0x3C,0x3C,0x3C,0x3C,0x3C};
```

---

## Mix and match ...

- Many of these different techniques can be combined
- For example, using the one-year and one-task schedulers together will further reduce current consumption.
- For example, using the “stable scheduler” as the Master node in a multi-processor system will improve the time-keeping in the whole network

[More on this in later seminars ...]

---

## Preparations for the next seminar

In the next seminar we'll discuss the use of watchdog timers with embedded systems.

You'll find some information about this topic in PTTES (Chapter 12).

You'll find a more detailed version of the material introduced in the next seminar in this paper:

Pont, M.J. and Ong, H.L.R. (2002) "Using watchdog timers to improve the reliability of TTCS embedded systems: Seven new patterns and a case study", to appear in the proceedings of VikingPLOP 2002, Denmark, September 2002.

A copy is available on the following WWW site:

<http://www.engg.le.ac.uk/books/Pont/downloads.htm>

You may find it useful to have a copy of this paper with you at the seminar.

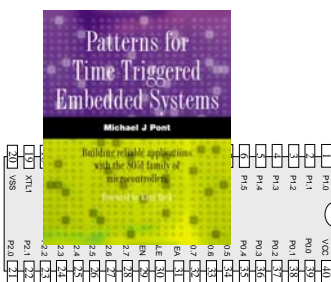





---

# **Seminar 5:**

## Improving system reliability using watchdog timers

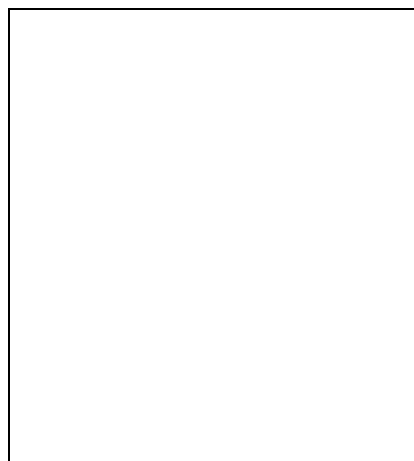

---

## Overview of this seminar

In this seminar we'll discuss the use of watchdog timers with embedded systems.

You'll find a more detailed version of the material introduced in this seminar in this paper:

Pont, M.J. and Ong, H.L.R. (2002) "Using watchdog timers to improve the reliability of TTCSS embedded systems: Seven new patterns and a case study", to appear in the proceedings of VikingPLOP 2002, Denmark, September 2002.

A copy is available on the following WWW site:

<http://www.engg.le.ac.uk/books/Pont/downloads.htm>

You may find it useful to have a copy of this paper with you at the seminar.

---

## The watchdog analogy

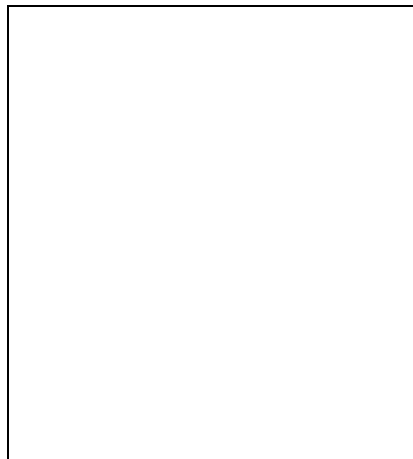

Watchdog timers will - usually - have the following two features:

- The timer must be refreshed at regular, well-defined, intervals.

If the timer is not refreshed at the required time it will overflow, an process which will usually cause the associated microcontroller to be reset.

- When starting up, the microcontroller can determine the cause of the reset.

That is, it can determine if it has been started ‘normally’, or re-started as a result of a watchdog overflow. This means that, in the latter case, the programmer can ensure that the system will try to handle the error that caused the watchdog overflow.

---

## **PATTERN: Watchdog Recovery**

Understanding the basic operation of watchdog timer hardware is not difficult.

However, making good use of this hardware in a TTCS application requires some care. As we will see, there are three main issues which need to be considered:

- Choice of hardware;
- The watchdog-induced reset;
- The recovery process.

---

## Choice of hardware

We have seen in many previous cases that, where available, the use of on-chip components is to be preferred to the use of equivalent off-chip components. Specifically, on-chip components tend to offer the following benefits:

- Reduced hardware complexity, which tends to result in increased system reliability.
- Reduced application cost.
- Reduced application size.

These factors also apply when selecting a watchdog timer.

In addition, when implementing **WATCHDOG RECOVERY**, it is usually important that the system is able to determine - as it begins operation - whether it was reset as a result of normal power cycling, or because of a watchdog timeout.

**In most cases, only on-chip watchdogs allow you to determine the cause of the reset in a simple and reliable manner.**

---

## Time-based error detection

A key requirement in applications using a co-operative scheduler is that, for all tasks, under all circumstances, the following condition must be adhered to:

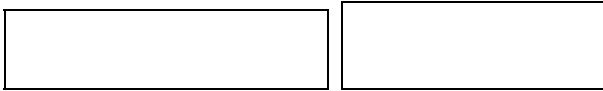

Where:  is the task duration, and  is the system 'tick interval'.

It is possible to use a watchdog timer to detect task overflows, as follows:

- Set the watchdog timer to overflow at a period greater than the tick interval.
- Create a task that will update the watchdog timer shortly before it overflows.
- Start the watchdog.

[We'll say more about this shortly]

---

## Other uses for watchdog-induced resets

If your system uses timer-based error detection techniques, then it can make sense to also use watchdog-induced resets to handle other errors. Doing this means that you can integrate some or all of your error-handling mechanisms in a single place (usually in some form of system initialisation function). This can - in many systems - provide a very “clean” and approach to error handling that is easy to understand (and maintain).

Note that this combined approach is only appropriate where the recovery behaviour you will implement is the **same** for the different errors you are trying to detect.

Here are some suggestions for the types of errors that can be effectively handled in this way:

- Failure of on-chip hardware (e.g. analogue-to-digital converters, ports).
- Failure of external actuators (e.g. DC motors in an industrial robot; stepper motors in a printer).
- Failure of external sensors (e.g. ultraviolet sensor in an art gallery; vibration sensor in an automotive system).
- Temporary reduction in power-supply voltage.

---

## Recovery behaviour

Before we decide whether we need to carry out recovery behaviour, we assume that the system has been reset.

If the reset was “normal” we simply start the scheduler and run the standard system configuration.

If, instead, the cause of the reset was a watchdog overflow, then there are three main options:

- We can simply continue **as if** the processor had undergone an “ordinary” reset.
- We can try to “freeze” the system in the reset state. This option is known as “fail-silent recovery”.
- We can try to have the system run a different algorithm (typically, a very simple version of the original algorithm, often without using the scheduler). This is often referred to as “limp home recovery”.



---

## Risk assessment

In safety-related or safety-critical systems, this pattern should not be implemented before a **complete risk-assessment study** has been conducted (by suitably-qualified individuals).

Successful use of this pattern requires a full understanding of the errors that are likely to be detected by your error-detection strategies (and those that will be missed), plus an equal understanding of the recovery strategy that you have chosen to implement.

Without a complete investigation of these issues, you cannot be sure that implementation of the pattern you will increase (rather than decrease) the reliability of your application.

---

## The limitations of single-processor designs

It is important to appreciate that there is a limit to the extent to which reliability of a single-processor embedded system can be improved using a watchdog timer.

For example, **LIMP-HOME RECOVERY** is the most sophisticated recovery strategy considered in this seminar.

If implemented with due care, it can prove very effective. However, it relies for its operation on the fact that - even in the presence of an error - the processor itself (and key support circuitry, such as the oscillator, power supply, etc) still continues to function. If the processor or oscillator suffer physical damage, or power is removed, **LIMP-HOME RECOVERY** cannot help your system to recover.

In the event of physical damage to your “main” processor (or its support hardware), you may need to have some means of engaging another processor to take over the required computational task.

---

## Time, time, time ...

Suppose that the braking system in an automotive application uses a 500 ms watchdog and the vehicle encounters a problem when it is travelling at 70 miles per hour (110 km per hour).

In these circumstances, the vehicle and its passengers will have travelled some 15 metres / 16 yards - right into the car in front - before the vehicle even begins to switch to a “limp-home” braking system.

In some circumstances, the programmer can reduce the delays involved with watchdog-induced resets.

For example, using the Infineon C515C:

```
/* Set up the watchdog for "normal" use  
  - overflow period = ~39 ms */  
WDTREL = 0x00;  
  
...  
  
/* Adjust watchdog timer for faster reset  
  - overflow set to ~300 µs */  
WDTREL = 0x7F;  
  
/* Now force watchdog-induced reset */  
while(1)  
    ;
```

---

## Watchdogs: Overall strengths and weaknesses

- ☺ **Watchdogs can provide a ‘last resort’ form of error recovery. If you think of the use of watchdogs in terms of ‘if all else fails, then we’ll let the watchdog reset the system’, you are taking a realistic view of the capabilities of this approach.**
- ☹ Use of this technique usually requires an on-chip watchdog.
- ☹ Used without due care at the design phase and / or adequate testing, watchdogs can reduce the system reliability dramatically. In particular, in the presence of sustained faults, badly-designed watchdog “recovery” mechanisms can cause your system to repeatedly reset itself. **This can be very dangerous.**
- ☹ Watchdogs with long timeout periods are unsuitable for many applications.

---

## PATTERN: Scheduler Watchdog

As we have mentioned, a key requirement in applications using a co-operative scheduler is that, for all tasks, under all circumstances, the following condition must be adhered to:

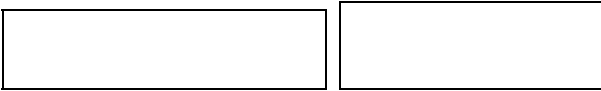

Where:  is the task duration, and  is the system 'tick interval'.

It is possible to use a watchdog timer to detect task overflows, as follows:

- Set the watchdog timer to overflow at a period greater than the tick interval.
- Create a task that will update the watchdog timer shortly before it overflows.
- Start the watchdog.

So - how do you select the watchdog overflow period?

---

## Selecting the overflow period - “hard” constraints

For systems with “hard” timing constraints for one or more tasks, it is usually appropriate to set the watchdog overflow period to a value slightly greater than the tick interval (e.g. 1.1 ms overflow in a system with 1 ms ticks).

Please note that to do this, the watchdog timer will usually need to be driven by a crystal oscillator (or the timing will not be sufficiently accurate).

In addition, the watchdog timer will need to give you enough control over the timer settings, so that the required overflow period can be set.

---

## Selecting the overflow period - “soft” constraints

Many ('soft') TTCS systems continue to operate safely and effectively, even if - **occasionally** - the duration of the task(s) that are scheduled to run at a particular time exceeds the tick interval.

To give a simple example, a scheduler with a 1 ms tick interval can - without problems - schedule a single task with a duration of 10 ms that is called every 20 ms.

Of course, if the same system is also trying to schedule a task of duration 0.1 ms every 5 ms, then the 0.1 ms task will sometimes be blocked. Often careful design will avoid this blockage but - even if it occurs - it still may not matter because, although the 0.1 ms will not always run on time, it will always run (that is, it will run 200 times every second, as required).

For some tasks - with soft deadlines - this type of behaviour may be acceptable. If so:

- Set the watchdog to overflow after a period of around 100 ms.
- Feed the watchdog every millisecond, using an appropriate task.
- Only if the scheduling is blocked for more than 100 ms will the system be reset.

---

## **PATTERN: Program-Flow Watchdog**

Use of **PROGRAM-FLOW WATCHDOG** may help to improve reliability of your system in the presence of program-flow errors (which may, in turn, result from EMI).

Arguably, the most serious form of program-flow error in an embedded microcontroller is corruption of the program counter (PC), also known as the instruction pointer.

Since the PC of the 8051 is a 16-bit wide register, we make the reasonable assumption that – in response to PC corruption – the PC may take on any value in the range 0 to 65535. In these circumstances, the 8051 processor will fetch and execute the next instruction from the code memory location pointed to by the corrupted PC register. **This can be very dangerous!**



---

The most straightforward implementation of **PROGRAM-FLOW WATCHDOG** involves two stages:

- We fill unused locations at the end of the program code memory with single-byte “No Operation” (NOP), or equivalent, instructions.
- We place a “PC Error Handler” (PCEH) at the end of code memory to deal with the error.

---

## Dealing with errors

Here, we will assume that the PCEH will consist mainly of a loop:

```
/* Force watchdog timeout */  
while(1)  
    ;
```

This means that, as discussed in **WATCHDOG RECOVERY** [this seminar] the watchdog timer will force a clean system reset.

Please note that, as also discussed in **WATCHDOG RECOVERY**, we may be able to reduce the time taken to reset the processor by adapting the watchdog timing. For example:

```
/* Set up the watchdog for "normal" use  
  - overflow period = ~39 ms */  
WDTREL = 0x00;  
  
...  
  
/* Adjust watchdog timer for faster reset  
  - overflow set to ~300 µs */  
WDTREL = 0x7F;  
  
/* Now force watchdog-induced reset */  
while(1)  
    ;
```

After the watchdog-induced reset, we need to implement a suitable recovery strategy. A range of different options are discussed in **RESET RECOVERY** [this seminar], **FAIL-SILENT RECOVERY** [this seminar] and **LIMP-HOME RECOVERY** [this seminar].

---

## Hardware resource implications

**PROGRAM-FLOW WATCHDOG** can only be guaranteed to work where the corrupted PC points to an “empty” memory location.

Maximum effectiveness will therefore be obtained with comparatively small programs (a few kilobytes of code memory), and larger areas of empty memory.

If devices with less than 64kB of code memory are used, a problem known as “memory aliasing” can occur:

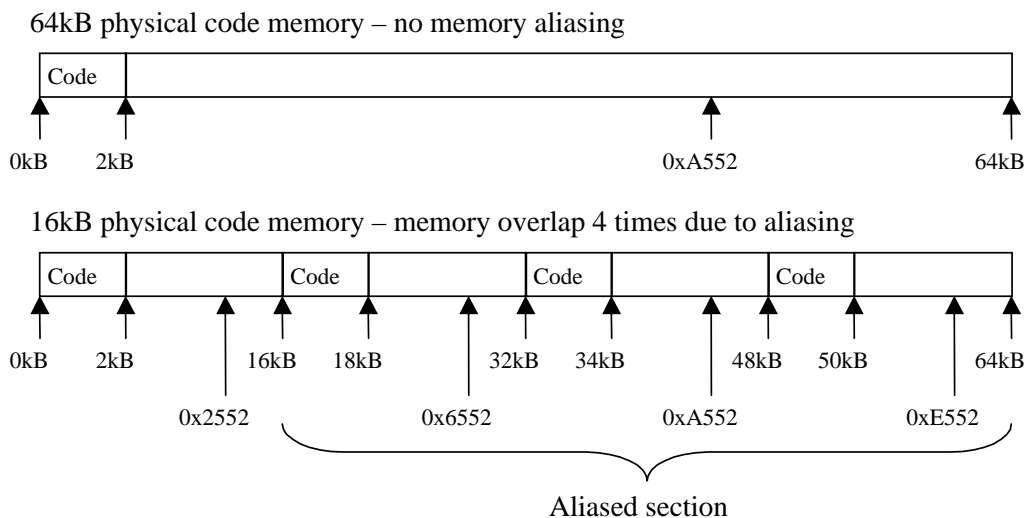

If you want to increase the chances of detecting program-flow errors using this approach, you need to use the maximum amount of (code) memory that is supported by your processor. In the case of the 8051 family, this generally means selecting a device with 64 kB of memory. Clearly, this choice will have cost implications.

---

## Speeding up the response

We stated in “Solution” that the most straightforward implementation of **PROGRAM-FLOW WATCHDOG** involves two stages:

- We fill unused locations at the end of the program code memory with single-byte “No Operation” (NOP), or equivalent, instructions.
- Second, a small amount of program code, in the form of an “PC Error Handler” (PCEH), is placed at the end of code memory to deal with the error.

Two problems:

- It may take an appreciable period of time for the processor to reach the error handler.
- The time taken to recover from an error is highly variable (since it depends on the value of the corrupted PC).

---

An alternative is to fill the memory not with “NOP” instructions but with “jump” instructions.

(In effect, we want to fill each location with “Jump to address X” instructions, and then place the error handler at address X.)

- In the 8051, the simplest implementation is to fill the empty memory with “long jump” instructions (0x02).
- The error handler will then be located at address 0x0202.

---

## **PATTERN: Reset Recovery**

Using **RESET RECOVERY** we assume that the best way to deal with an error (the presence of which is indicated by a watchdog-induced reset) is to re-start the system, in its normal configuration.

### **Implementation**

**RESET RECOVERY** is very to easy to implement. We require a basic watchdog timer, such as the common “1232” external device, available from various manufacturers (we show how to use this device in an example below).

Using such a device, the cause of a system reset cannot be easily determined. However, this does not present a problem when implementing **RESET RECOVERY**. After any reset, we simply start (or re-start) the scheduler and **try** to carry out the normal system operations.

The particular problem with **RESET RECOVERY** is that, if the error that gave rise to the watchdog reset is permanent (or long-lived), then you are likely to lose control of your system as it enters an endless loop (reset, watchdog overflow, reset, watchdog overflow, ...).

**This lack of control can have disastrous consequences in many systems.**

---

## **PATTERN: Fail-Silent Recovery**

When using **FAIL-SILENT RECOVERY**, our aim is to shut the system down after a watchdog-induced reset. This type of response is referred to as “fail silent” behaviour because the processor becomes “silent” in the event of an error.

**FAIL-SILENT RECOVERY** is implemented after every “Normal” reset as follows:

- The scheduler is started and program execution is normal.

By contrast, after a watchdog-induced reset, **FAIL-SILENT RECOVERY** will typically be implemented as follows:

- Any necessary port pins will be set to appropriate levels (for example, levels which will shut down any attached machinery).
- Where required, an error port will be set to report the cause of the error,
- All interrupts will be disabled, and,
- The system will be stopped, either by entering an endless loop or (preferably) by entering power-down or idle mode.

(Power-down or idle mode is used because, in the event that the problems were caused by EMI or ESD, this is thought likely to make the system more robust in the event of another interference burst.)

---

## Example: Fail-Silent behaviour in the Airbus A310

- In the A310 Airbus, the slat and flap control computers form an ‘intelligent’ actuator sub-system.
- If an error is detected during landing, the wings are set to a safe state and then the actuator sub-system shuts itself down (Burns and Wellings, 1997, p.102).

[Please note that the mechanisms underlying this “fail silent” behaviour are unknown.]



---

## Example: Fail-Silent behaviour in a steer-by-wire application

Suppose that an automotive steer-by-wire system has been created that runs a single task, every 10 ms. We will assume that the system is being monitored to check for task over-runs (see **SCHEDULER WATCHDOG** [this seminar]). We will also assume that the system has been well designed, and has appropriate timeout code, etc, implemented.

Further suppose that a passenger car using this system is being driven on a motorway, and that an error is detected, resulting in a watchdog reset. What recovery behaviour should be implemented?

We could simply re-start the scheduler and “hope for the best”. However, this form of “reset recovery” is probably not appropriate. In this case, if we simply perform a reset, we may leave the driver without control of their vehicle (see **RESET RECOVERY** [this seminar]).

Instead, we could implement a fail-silent strategy. In this case, we would simply aim to bring the vehicle, slowly, to a halt. To warn other road vehicles that there was a problem, we could choose to flash all the lights on the vehicle on an off (continuously), and to pulse the horn. This strategy (which may - in fact - be far from silent) is not ideal, because there can be no guarantee that the driver and passengers (or other road vehicles) will survive the incident. However, in the event of a very serious system failure, it may be all that we can do.

---

## **PATTERN: Limp-Home Recovery**

In using **LIMP-HOME RECOVERY**, we make two assumptions about our system:

- A watchdog-induced reset indicates that a significant error has occurred.
- Although a full (normal) re-start is considered too risky, it may still be possible to let the system “limp home” by running a simple version of the original algorithm.

Overall, in using this pattern, we are looking for ways of ensuring that the system continues to function - even in a very limited way - in the event of an error.

**LIMP-HOME RECOVERY** is implemented after every “Normal” reset as follows:

- The scheduler is started and program execution is normal.

By contrast, after a watchdog-induced reset, **LIMP-HOME RECOVERY** will typically be implemented as follows:

- The scheduler will not be started.
- A simple version of the original algorithm will be executed.

---

## Example: Limp-home behaviour in a steer-by-wire application

In **FAIL-SILENT RECOVERY** [this seminar], we considered one possible recovery strategy in a steer-by-wire application.

As an alternative to the approach discussed in the previous example, we may wish to consider a limp-home control strategy. In this case, a suitable strategy might involve a code structure like this:

```
while(1)
{
    Update_basic_steering_control();
    Software_delay_10ms();
}
```

This is a basic software architecture (based on **SUPER LOOP** [PTTES, p.162]).

In creating this version, we have avoided use of the scheduler code. We might also wish to use a different (simpler) control algorithm at the heart of this system. For example, the main control algorithm may use measurements of the current speed, in order to ensure a smooth response even when the vehicle is moving rapidly. We could omit this feature in the “limp home” version.

- 
- Of course, simply using a different software implementation **may still not be enough**.

For example, in our steer-by-wire application, we may have a position sensor (attached to the steering column) and an appropriate form of DC motor (attached to the steering rack). Both the sensor and the actuator would then be linked to the processor.

- When designing the limp-home controller, we would like to have an additional sensor and actuator, which are - as far as possible - independent of the components used in the main (scheduled) system.
- This option makes sense because it is likely to maximise the chances that the Slave node will operate correctly when it takes over.

---

This approach has two main implications:

1. The hardware **must** ‘fail silently’: for example, if we did add a backup motor to the steering rack, this would be little use if the main motor ‘seized’ when the scheduler task was shut down.

Note that there may be costs associated with obtaining this behaviour. For example, we may need to add some kind of clutch assembly to the motor output, to ensure that it could be disconnected in the event of a motor jam. However, such a decision would need to be made only after a full risk assessment. For example, it would not make sense to add a clutch unit if a failure of this unit (leading to a loss of control of steering) was more likely than a motor seizure.

2. The cost of hardware duplication can be significant, and will often be considerably higher than the cost of a duplicated processor: this may make this approach economically unfeasible.

When costs are too high, sometimes a compromise can prove effective. For example, in the steering system, we might consider adding a second set of windings to the motor for use by the Slave (rather than adding a complete new motor assembly). Again, such a decision should be made only after a full risk assessment.

---

## PATTERN: Oscillator Watchdog

People sometimes assume that watchdog timer is a good way of detecting oscillator failure. However, a few moments thought quickly reveals that this is very rarely the case.

When the oscillator fails, the associated microcontroller will stop.

Even if (by using a watchdog timer, or some other technique) you detect that the oscillator has failed, you cannot execute any code to deal with the situation.

In these circumstances, you may be able to improve the reliability of your system by using an *oscillator watchdog*.

The OW operates as follows: if an oscillator failure is detected, the microcontroller is forced into a reset state: **this means that port pins take on their reset values.**

The state of the port pins is crucial, since it means that the developer has a chance to ensure that hardware devices controlled by the processor (for example, dangerous machinery) will be shut down if the oscillator fails.

---

## What happens next?

- In most cases, the microcontroller will be held in a reset state “for ever”.
- However, most oscillator watchdogs will continue to monitor the clock input to the chip: if the main oscillator is restored, the system will leave reset and will begin operating again.

---

## Preparations for the next seminar

In the next seminar, we will begin to consider techniques for linking together multiple processors.

Please read PTTES Chapter 25 before the next seminar.

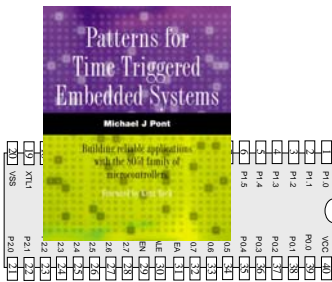



---

# Seminar 6:

## Shared-clock schedulers for multi- processor systems

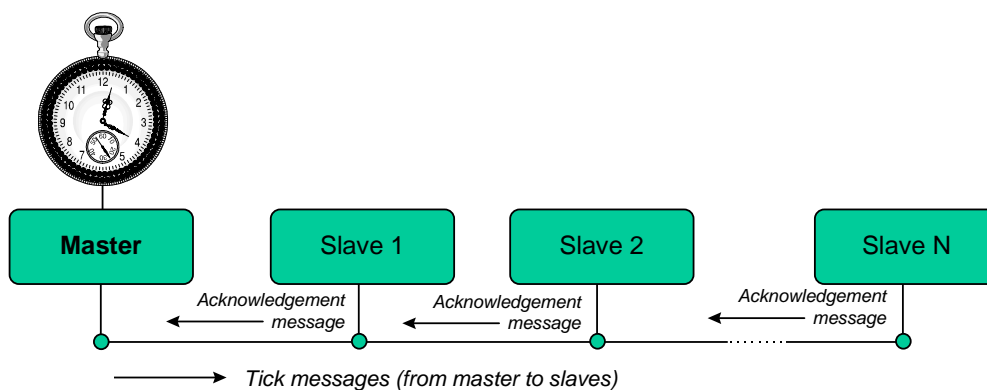

---

## Overview of this seminar

We now turn our attention to multi-processor applications. As we will see, an important advantage of the time-triggered (co-operative) scheduling architecture is that it is inherently scaleable, and that its use extends naturally to multi-processor environments.

In this seminar:

- We consider some of the advantages - and disadvantages - that can result from the use of multiple processors.
- We introduce the **shared-clock scheduler**.
- We consider the implementation of shared-clock designs schedulers that are kept synchronised through the use of external interrupts on the Slave microcontrollers.

---

## Why use more than one processor?

Many modern embedded systems contain more than one processor.

For example, a modern passenger car might contain some forty such devices, controlling brakes, door windows and mirrors, steering, air bags, and so forth.

Similarly, an industrial fire detection system might typically have 200 or more processors, associated - for example - with a range of different sensors and actuators.

Two main reasons:

- Additional CPU performance and hardware facilities
- Benefits of modular design

---

## Additional CPU performance and hardware facilities

Suppose we require a microcontroller with the following specification:

- 60+ port pins
- Six timers
- Two USARTS
- 128 kbytes of ROM
- 512 bytes of RAM
- A cost of around \$1.00 (US)

... how can we achieve this???

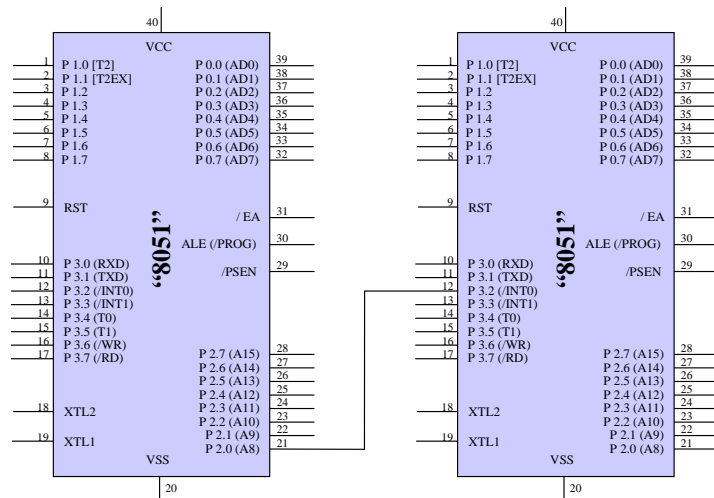

- A flexible environment with 62 free port pins, 5 free timers, two UARTs, etc.
- Further microcontrollers may be added without difficulty,
- The communication over a single wire (plus ground) will ensure that the tasks on all processors are synchronised.
- The two-microcontroller design also has two CPUs: true multi-tasking is possible.

---

## The benefits of modular design

Suppose we want to build a range of clocks...

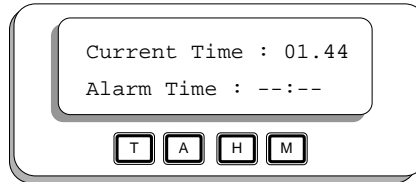

We can split the design into ‘display’ and ‘time-keeping’ modules.

This type of modular approach is very common in the automotive industry where increasing numbers of microcontroller-based modules are used in new vehicle designs.

---

## The benefits of modular design

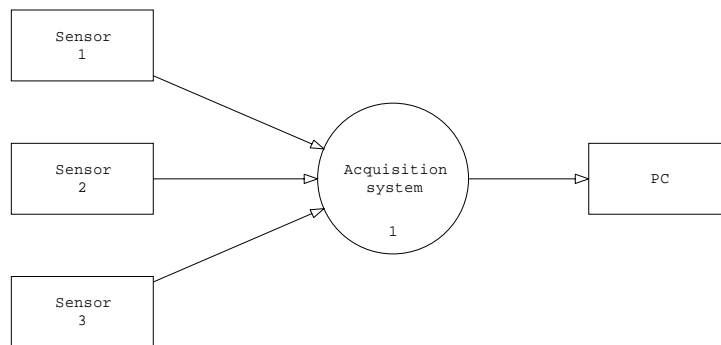

An alternative solution:

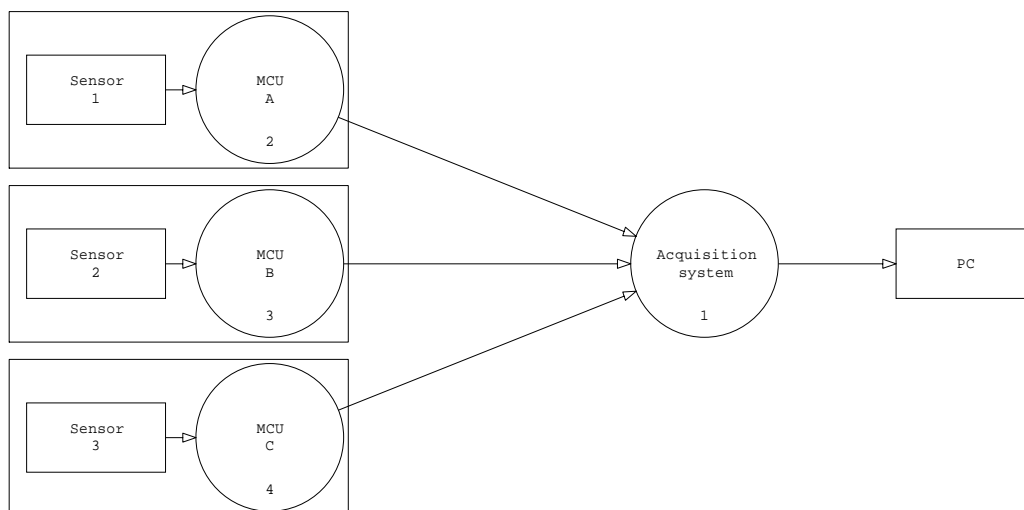

In the A310 Airbus, the slat and flap control computers form an ‘intelligent’ actuator sub-system. If an error is detected during landing, the wings are set to a safe state and then the actuator sub-system shuts itself down.

---

## So - how do we link more than one processor?

Some important questions:

- How do we keep the clocks on the various nodes synchronised?
- How do we transfer data between the various nodes?
- How does one node check for errors on the other nodes?



---

## Synchronising the clocks

Why do we need to synchronise the tasks running on different parts of a multi-processor system?

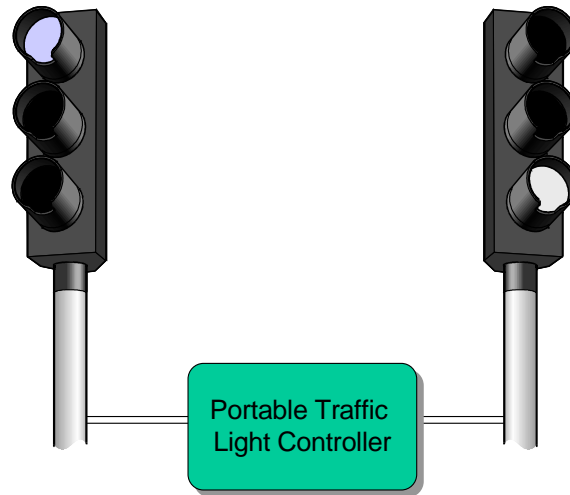

- We will assume that there will be a microcontroller at each end of the traffic light application to control the two sets of lights.
- We will also assume that each microcontroller is running a scheduler, and that each is driven by an independent crystal oscillator circuit.

**BUT!**

Each microcontroller will operate at a different temperature...

The lights will get “out of sync”...

---

## Synchronising the clocks

The S-C scheduler tackles this problem by sharing a single clock between the various processor board:

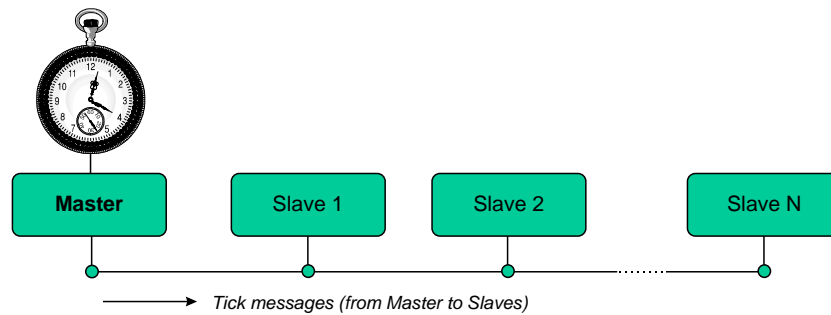

Here we have one, accurate, clock on the Master node in the network.

**This clock is used to drive the scheduler in the Master node in exactly the manner discussed in Seminar 1 and Seminar 2.**

---

## Synchronising the clocks - Slave nodes

The Slave nodes also have schedulers: however, the interrupts used to drive these schedulers are derived from ‘tick messages’ generated by the Master.

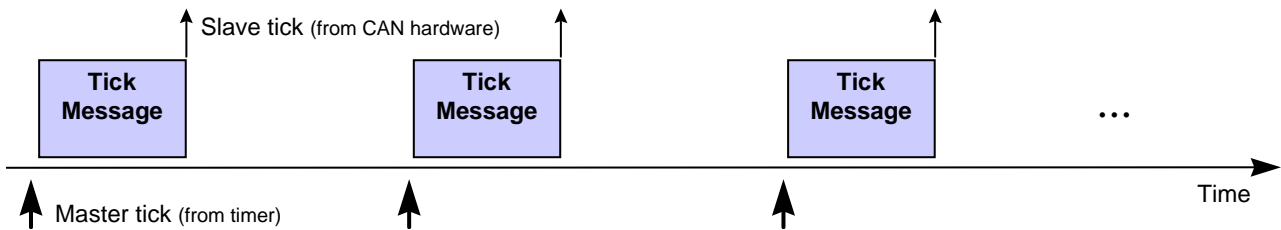

This keeps all the nodes running “in phase”

### For example:

In the case of the traffic lights considered earlier, changes in temperature will, at worst, cause the lights to cycle more quickly or more slowly: the two sets of lights will not, however, get out of sync.

---

## Transferring data

In many applications, we will also need to **transfer data** between the tasks running on different processor nodes.

To illustrate this, consider again the traffic-light controller. Suppose that a bulb blows in one of the light units.

- When a bulb is missing, the traffic control signals are ambiguous: we therefore need to detect bulb failures on each node and, having detected a failure, notify the other node that a failure has occurred.
- This will allow us - for example - to extinguish all the (available) bulbs on both nodes, or to flash all the bulbs on both nodes: in either case, this will inform the road user that something is amiss, and that the road must be negotiated with caution.

---

## Transferring data (Master to Slave)

As we discussed above, the Master sends regular tick messages to the Slave, typically once per millisecond.

These tick messages can - in most S-C schedulers - include data transfers: it is therefore straightforward to send an appropriate tick message to the Slave to alert it to the bulb failure.

---

## Transferring data (Slave to Master)

To deal with the transfer of data from the Slave to the Master, we need an additional mechanism: this is provided through the use of ‘Acknowledgement’ messages:

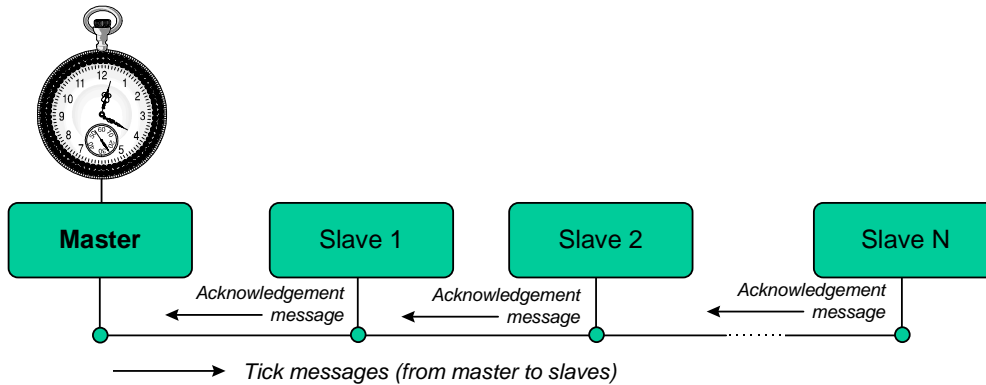

This is a ‘time division multiple access’ (TDMA) protocol, in which the acknowledgement messages are interleaved with the Tick messages.

---

## Transferring data (Slave to Master)

This figure shows the mix of Tick and Acknowledgement messages that will typically be transferred in a two-Slave (CAN) network.

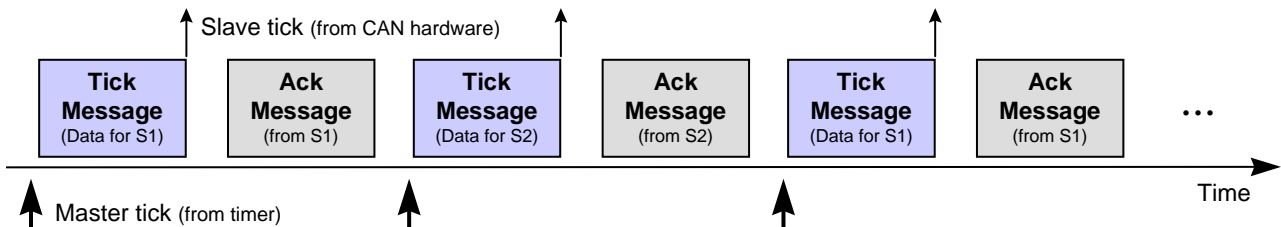

**Note** that, in a shared-clock scheduler, *all* data transfers are carried out using the interleaved Tick and Acknowledgement messages: no additional messages are permitted on the bus. As a result, we are able to determine precisely the network bandwidth required to ensure that all messages are delivered precisely on time.

---

## Detecting network and node errors

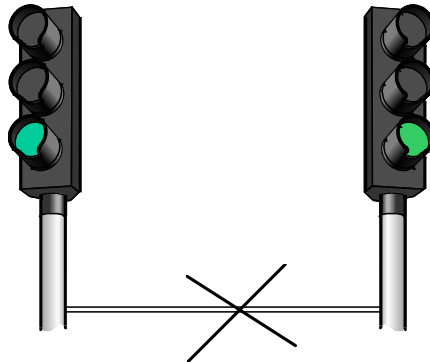

How do we detect this (and other errors)?

What should we do?



---

## Detecting errors in the Slave(s)

- We know from the design specification that the Slave should receive ticks at precise intervals of time (e.g. every 10 ms)
- Because of this, we simply need to measure the time interval between ticks; if a period greater than the specified tick interval elapses between ticks, we can safely conclude that an error has occurred.
- In many circumstances an effective way of achieving this is to set a **watchdog timer** in the Slave to overflow at a period slightly longer than the tick interval (we discussed watchdog timers in Seminar 5).
- If a tick is not received, then the timer will overflow, and we can invoke an appropriate error-handling routine.

---

## Detecting errors in the Master

Detecting errors in the Master node requires that each Slave sends appropriate acknowledgement messages to the Master at regular intervals.

Considering the operation of a particular 1-Master, 10-Slave network:

- The Master node sends tick messages to all nodes, simultaneously, every millisecond; these messages are used to invoke the Update function in all Slaves (every millisecond).
- Each tick message may include data for a particular node. In this case, we will assume that the Master sends tick messages to each of the Slaves in turn; thus, each Slave receives data in every tenth tick message (every 10 milliseconds in this case).
- Each Slave sends an acknowledgement message to the Master only when it receives a tick message with its ID; it does **not** send an acknowledgement to any other tick messages.

This arrangement provides the predictable bus loading that we require, and a means of communicating with each Slave individually.

It also means that the Master is able to detect whether or not a particular Slave has responded to its tick message.

---

## Handling errors detected by the Slave

We will assume that errors in the Slave are detected with a watchdog timer. To deal with such errors, the shared-clock schedulers considered on this course all operate as follows:

- Whenever the Slave node is reset (either having been powered up, or reset as a result of a watchdog overflow), the node enters a ‘safe state’.
- The node remains in this state until it receives an appropriate series of ‘start’ commands from the Master.

This form of error handling is easily produced, and is effective in most circumstances.

---

## Handling errors detected by the Master

Handling errors detected by the Master is more complicated.

We will consider and illustrate three main options in this course:

- The ‘Enter safe state then shut down’ option, and,
- The ‘Restart the network’ option, and
- The ‘Engage replacement Slave’ option.

---

## Enter a safe state and shut down the network

Shutting down the network following the detection of errors by the Master node is easily achieved: we simply stop the transmission of tick messages by the Master.

By stopping the tick messages, we cause the Slave(s) to be reset too; the Slaves will then wait (in a safe state). The whole network will therefore stop, until the Master is reset.

This behaviour is the most appropriate behaviour in many systems in the event of a network error, **if a 'safe state' can be identified.** This will, of course, be highly application-dependent.

- ☺ **It is very easy to implement.**
- ☺ **It is effective in many systems.**
- ☺ **It can often be a 'last line of defence' if more advanced recovery schemes have failed.**
- ☹ It does not attempt to recover normal network operation, or to engage backup nodes.

---

## Reset the network

Another simple way of dealing with errors is to reset the Master and - hence - the whole network.

When it is reset, the Master will attempt to re-establish communication with each Slave in turn; if it fails to establish contact with a particular Slave, it will attempt to connect to the backup device for that Slave.

This approach is easy to implement and can be effective. For example, many designs use ‘N-version’ programming to create backup versions of key components. By performing a reset, we keep all the nodes in the network synchronised, and we engage a backup Slave (if one is available).

- ☺ **It allows full use to be made of backup nodes.**
- ☹ It may take time (possibly half a second or more) to restart the network; even if the network becomes fully operational, the delay involved may be too long (for example, in automotive braking or aerospace flight-control applications).
- ☹ With poor design or implementation, errors can cause the network to be continually reset. This may be rather less safe than the simple ‘enter safe state and shut down’ option.

---

## Engage a backup Slave

The third and final recovery technique we discuss in this course is as follows.

If a Slave fails, then - rather than restarting the whole network - we start the corresponding backup unit.

The strengths and weaknesses of this approach are as follows:

- ☺ **It allows full use to be made of backup nodes.**
- ☺ **In most circumstances it takes comparatively little time to engage the backup unit.**
- ☹ The underlying coding is more complicated than the other alternatives discussed in this course.

---

## Why additional processors may not improve reliability

Suppose that a network has 100 microcontrollers and that each of these devices is 99.99% reliable.

If the multi-processor application relies on the correct, simultaneous, operation of all 100 nodes, it will have an overall reliability of  $99.99\% \times 99.99\% \times 99.99\% \dots$

**This is  $0.9999^{100}$ , or approximately 37%.**

A 99.99% reliable device might be assumed to fail once in 10,000 years, while the corresponding 37% reliable device would then be expected to fail approximately every 18 months.

It is only where the **increase in reliability** resulting from the shared-clock design **outweighs** the **reduction in reliability** known to arise from the increased system complexity that an overall increase in system reliability will be obtained.

Unfortunately, making predictions about the costs and benefits (in reliability terms) of any complex design feature remains - in most non-trivial systems - something of a black art.



---

## Redundant networks do not guarantee increased reliability

- In 1974, in a Turkish Airlines DC-10 aircraft, the cargo door opened at high altitude.
- This event caused the cargo hold to depressurise, which in turn caused the cabin floor to collapse.
- The aircraft contained two (redundant) control lines, in addition to the main control system - **but all three lines were under the cabin floor.**
- Control of the aircraft was therefore lost and it crashed outside Paris, killing 346 people.

---

## Replacing the human operator - implications

- In many embedded applications, there is either no human operator in attendance, or the time available to switch over to a backup node (or network) is too small to make human intervention possible.
- In these circumstances, if the component required to detect the failure of the main node and switch in the backup node is complicated (as often proves to be the case), then this ‘switch’ component may itself be the source of severe reliability problems (see Leveson, 1995).

---

## Are multi-processor designs ever safe?

These observations should not be taken to mean that multi-processor designs are inappropriate for use in high-reliability applications. Multiple processors can be (and are) safely used in such circumstances.

However, all multi-processor developments must be approached with caution, and must be subject to particularly rigorous design, review and testing.

---

## Preparations for the next seminar

Please read “PTTES” Chapter 27 before the next seminar.

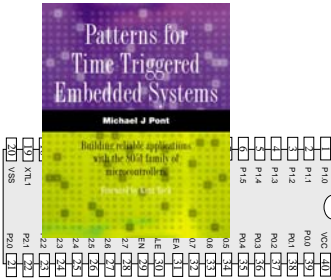

---

# Seminar 7:

## Linking processors using RS-232 and RS- 485 protocols

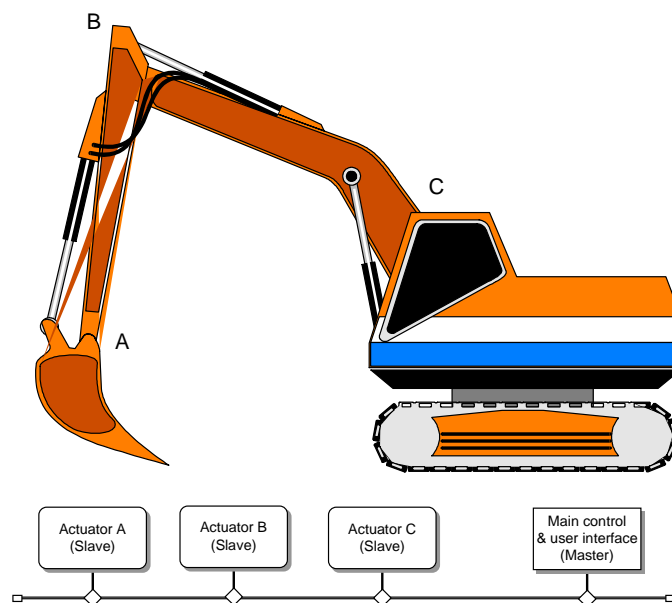

---

## Review: Shared-clock scheduling

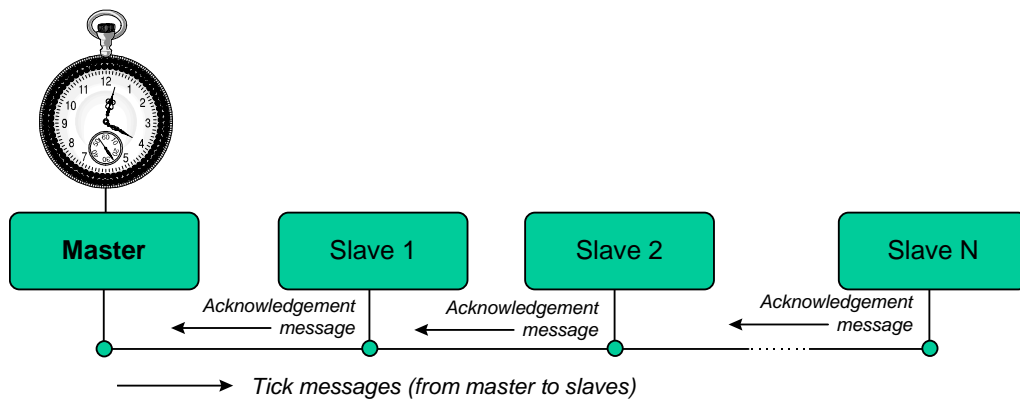

*Most S-C schedulers support both 'Tick' messages (sent from the Master to the Slaves), and 'Acknowledgement' messages (sent by the Slaves to the Master).*

---

## Overview of this seminar

In this seminar, we will discuss techniques for linking together two (or more) embedded processors, using the RS-232 and RS-485 protocols.

---

## Review: What is 'RS-232'?

In 1997 the Telecommunications Industry Association released what is formally known as TIA-232 Version F, a serial communication protocol which has been universally referred to as 'RS-232' since its first 'Recommended Standard' appeared in the 1960s. Similar standards (V.28) are published by the International Telecommunications Union (ITU) and by CCITT (The Consultative Committee International Telegraph and Telephone).

The 'RS-232' standard includes details of:

- The protocol to be used for data transmission.
- The voltages to be used on the signal lines.
- The connectors to be used to link equipment together.

Overall, the standard is comprehensive and widely used, at data transfer rates of up to around 115 or 330 kbits / second (115 / 330 k baud). Data transfer can be over distances of 15 metres or more.

Note that RS-232 is a peer-to-peer communication standard.



---

## Review: Basic RS-232 Protocol

RS-232 is a character-oriented protocol. That is, it is intended to be used to send single 8-bit blocks of data. To transmit a byte of data over an RS-232 link, we generally encode the information as follows:

- We send a ‘Start’ bit.
- We send the data (8 bits).
- We send a ‘Stop’ bit (or bits).

**REMEMBER: The UART takes care of these details!**

---

## Review: Transferring data to a PC using RS-232

Current core temperature  
is 36.678 degrees

All characters  
written immediately  
to buffer  
(very fast operation)

Buffer

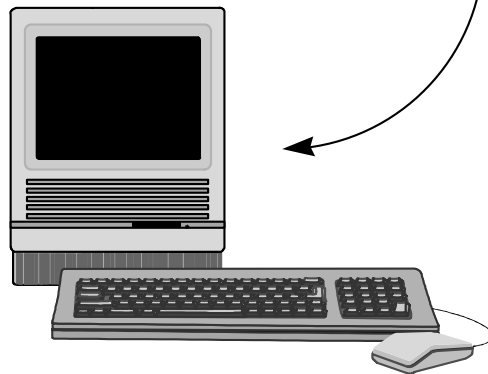

Scheduler sends one  
character to PC  
every 10 ms  
(for example)

---

## PATTERN: SCU SCHEDULER (LOCAL)

### Problem

How do you schedule tasks on (and transfer data over) a local network of two (or more) 8051 microcontrollers connected together via their UARTs?

### Solution

1. Timer overflow in the Master causes the scheduler 'Update' function to be invoked. This, in turn, causes a byte of data is sent (via the UART) to all Slaves:

```
void MASTER_Update_T2(void) interrupt INTERRUPT_Timer_2_Overflow
{
    ...

    MASTER_Send_Tick_Message(...);
    ...
}
```

2. When these data have been received all Slaves generate an interrupt; this invokes the 'Update' function in the Slave schedulers. This, in turn, causes one Slave to send an 'Acknowledge' message back to the Master (again via the UART).

```
void SLAVE_Update(void) interrupt INTERRUPT_UART_Rx_Tx
{
    ...
    SLAVE_Send_Ack_Message_To_Master();
    ...
}
```

---

## The message structure

Here we will assume that we wish to control and monitor three hydraulic actuators to control the operation of a mechanical excavator.

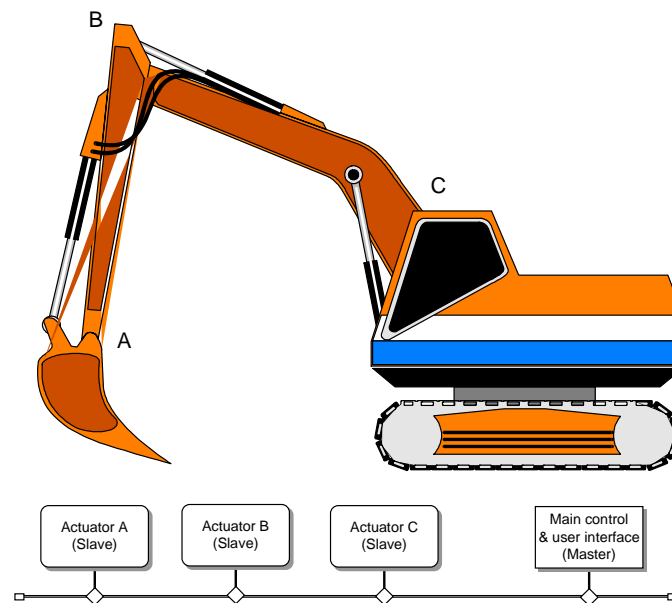

Suppose we wish to adjust the angle of Actuator A to 90 degrees; how do we do this?

Immediately the 8-bit nature of the UART becomes a limitation, because we need to send a message that identifies both the node to be adjusted, and the angle itself.

---

There is no ideal way of addressing this problem. Here, we adopt the following solution:

- Each Slave is given a unique ID (0x01 to 0xFF).
- Each Tick Message from the Master is two bytes long; these two bytes are sent one tick interval apart. The first byte is an ‘Address Byte’, containing the ID of the Slave to which the message is addressed. The second byte is the ‘Message Byte’ and contains the message data.
- All Slaves generate interrupts in response to each byte of every Tick Message.
- Only the Slave to which a Tick Message is addressed will reply to the Master; this reply takes the form of an Acknowledge Message.
- Each Acknowledge Message from a Slave is two bytes long; the two bytes are, again, sent one tick interval apart. The first byte is an ‘Address Byte’, containing the ID of the Slave from which the message is sent. The second byte is the ‘Message Byte’ and contains the message data.
- For data transfers requiring more than a single byte of data, multiple messages must be sent.

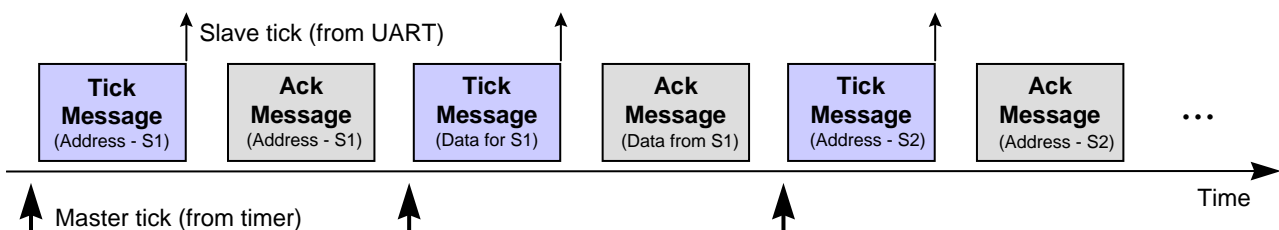

---

We want to be able to distinguish between ‘Address Bytes’ and ‘Data Bytes’.

We make use of the fact that the 8051 allows transmission of 9-bit serial data:

Description	Size (bits)
Data	9 bits
Start bit	1 bit
Stop bit	1 bit
<b>TOTAL</b>	<b>11 bits / message</b>

- In this configuration (typically, the UART used in Mode 3), 11 bits are transmitted / received. Note that the 9<sup>th</sup> bit is transmitted via bit TB8 in the register SCON, and is received as bit RB8 in the same register. In this mode, the baud rate is controlled as discussed in PTTES, Chapter 18.
- In the code examples presented here, Address Bytes are identified by setting the ‘command bit’ (TB8) to 1; Data Bytes set this bit to 0.

---

## Determining the required baud rate

- The timing of timer ticks in the Master is set to a duration such that one byte of a Tick Message can be sent (and one byte of an Acknowledge Message received) between ticks.
- Clearly, this duration depends on the network baud rate.
- As we discussed above, we will use a 9-bit protocol. Taking into account Start and Stop bits, we require 22 bits (11 for Tick message, 11 for Acknowledge message) per scheduler tick; that is, the required baud rate is: (Scheduler Ticks per second) x 22.

---

There is a delay between the timer on the Master and the UART-based interrupt on the Slave:

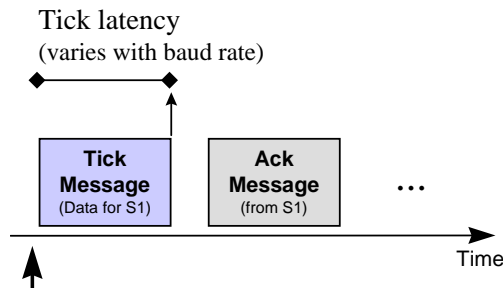

As discussed above, most shared-clock applications employ a baud rate of at least 28,800 baud: this gives a tick latency of approximately 0.4 ms. At 375,000 baud, this latency becomes approximately 0.03 ms.

Note that this latency is fixed, and can be accurately predicted on paper, and then confirmed in simulation and testing. If precise synchronisation of Master and Slave processing is required, then please note that:

- All the Slaves operate - within the limits of measurement - precisely in step.
- To bring the Master in step with the Slaves, it is necessary only to add a short delay in the Master 'Update' function.



# Node Hardware

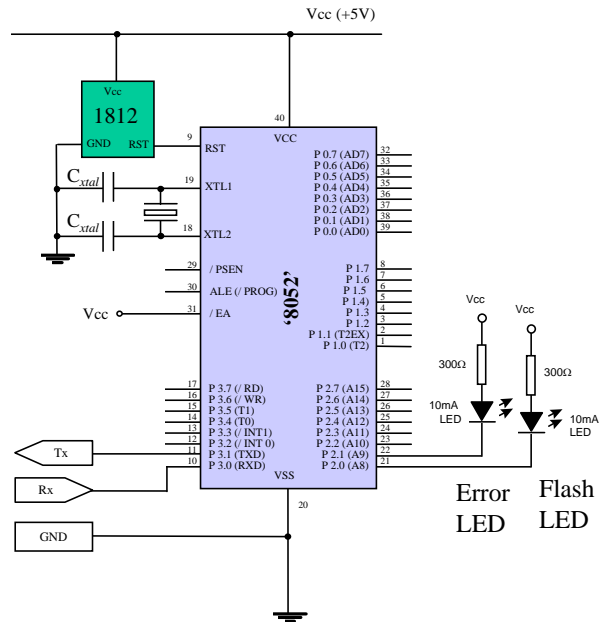
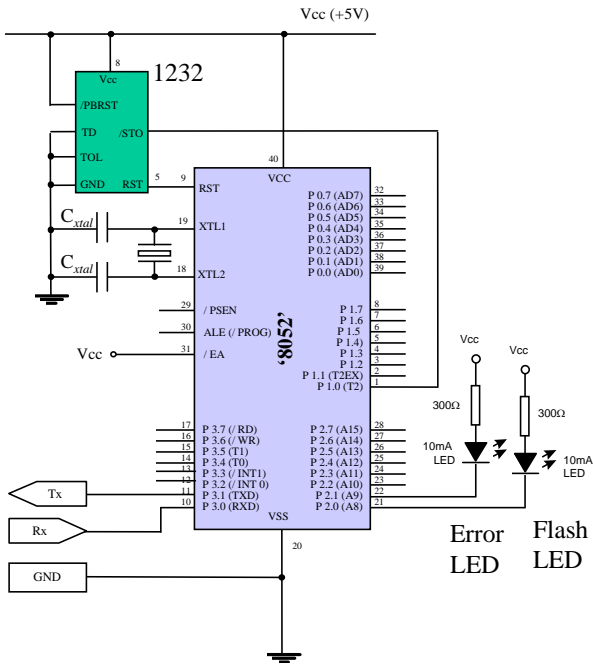

---

## Network wiring

Keep the cables short!

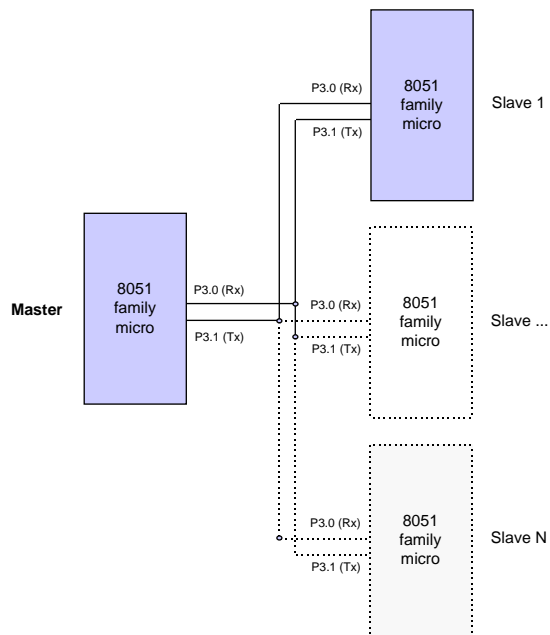
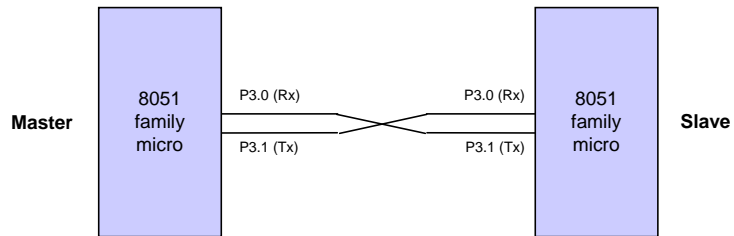

---

## Overall strengths and weaknesses

- ☺ **A simple scheduler for local systems with two or more 8051 microcontrollers.**
- ☺ **All necessary hardware is part of the 8051 core: as a result, the technique is very portable within this family.**
- ☺ **Easy to implement with minimal CPU and memory overheads.**
- ☹ The UART supports byte-based communications only: data transfer between Master and Slaves (and vice versa) is limited to 0.5 bytes per clock tick.
- ☹ Uses an important hardware resource (the UART)
- ☹ Most error detection / correction must be carried out in software
- ☹ This pattern is not suitable for distributed systems

## PATTERN: SCU Scheduler (RS-232)

### Context

- You are developing an embedded application using more than one member of the 8051 family of microcontrollers.
- The application has a time-triggered architecture, based on a scheduler.

### Problem

How do you schedule tasks on (and transfer data over) a distributed network of two 8051 microcontrollers communicating using the RS-232 protocol?

### Solution

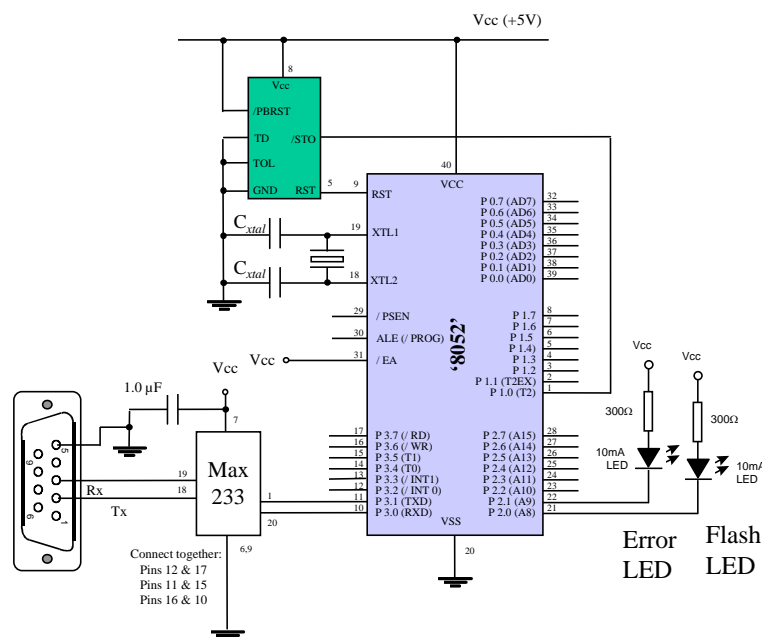

---

## **PATTERN: SCU Scheduler (RS-485)**

The communications standard generally referred to as ‘RS-485’ is an electrical specification for what are often referred to as ‘multi-point’ or ‘multi-drop’ communication systems; for our purposes, this means applications that involve at least three nodes, each containing a microcontroller.

Please note that the specification document (EIA/TIA-485-A) defines the electrical characteristics of the line and its drivers and receivers: this is limit of the standard. Thus, unlike ‘RS-232’, there is no discussion of software protocols or of connectors.

There are many similarities between RS-232 and RS-485 communication protocols:

- Both are serial standards.
- Both are in widespread use.
- Both involve - for our purposes - the use of an appropriate transceiver chip connected to a UART.
- Both involve very similar software libraries.

---

## RS-232 vs RS-485 [number of nodes]

- RS-232 is a peer-to-peer communications standard. For our purposes, this means that it is suitable for applications that involve two nodes, each containing a microcontroller (or, as we saw in PTTES, Chapter 18, for applications where one node is a desktop, or similar, PC).
- RS-485 is a ‘multi-point’ or ‘multi-drop’ communications standard. For our purposes, this means applications that involve at least three nodes, each containing a microcontroller. Larger RS-485 networks can have up to 32 ‘unit loads’: by using high-impedance receivers, you can have as many as 256 nodes on the network.

---

## RS-232 vs RS-485 [range and baud rates]

- RS-232 is a single-wire standard (one signal line, per channel, plus ground). Electrical noise in the environment can lead to data corruption. This restricts the communication range to a maximum of around 30 metres, and the data rate to around 115 kbaud (with recent drivers).
- RS-485 is a two-wire or differential communication standard. This means that, for each channel, two lines carry (1) the required signal and (2) the inverse of the signal. The receiver then detects the voltage *difference* between the two lines. Electrical noise will impact on both lines, and will cancel out when the difference is calculated at the receiver. As a result, an RS-485 network can extend as far as 1 km, at a data rate of 90 kbaud. Faster data rates (up to 10 Mbaud) are possible at shorter distances (up to 15 metres).

---

## RS-232 vs RS-485 [cabling]

- RS-232 requires low-cost ‘straight’ cables, with three wires for fully duplex communications (Tx, Rx, Ground).
- For full performance, RS-485 requires twisted-pair cables, with two twisted pairs, plus ground (and usually a screen). This cabling is more bulky and more expensive than the RS-232 equivalent.
- RS-232 cables do not require terminating resistors.
- RS-485 cables are usually used with  $120\Omega$  terminating resistors (assuming 24-AWG twisted pair cables) connected in parallel, at or just beyond the final node at **both** ends of the network. The terminations reduce voltage reflections that can otherwise cause the receiver to misread logic levels.

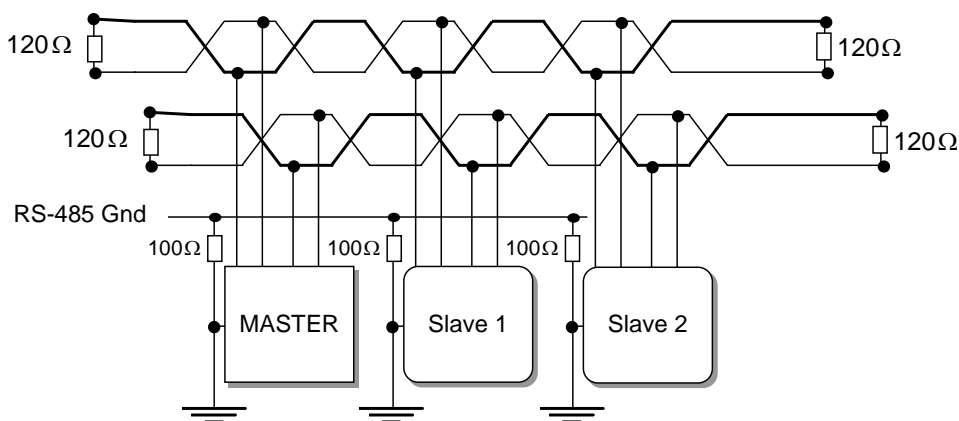



## RS-232 vs RS-485 [transceivers]

- RS-232 transceivers are simple and standard.
- Choice of RS-485 transceivers depends on the application. A common choice for basic systems is the Maxim Max489 family. For increased reliability, the Linear Technology LTC1482, National Semiconductors DS36276 and the Maxim MAX3080–89 series all have internal circuitry to protect against cable short circuits. Also, the Maxim Max MAX1480 contains its own transformer-isolated supply and opto-isolated signal path: this can help avoid interaction between power lines and network cables destroying your microcontroller.

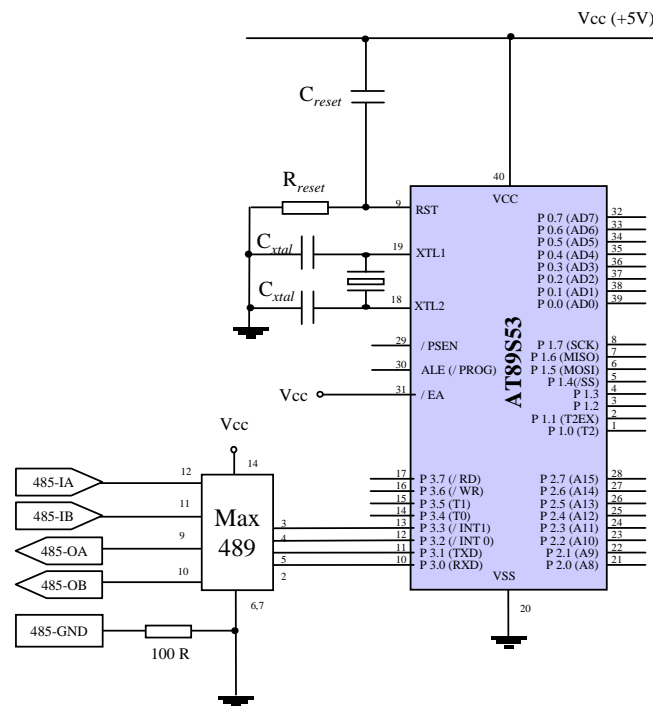

---

## Software considerations: enable inputs

The software required in this pattern is, in almost all respects, identical to that presented in **SCU SCHEDULER (LOCAL)**.

The only exception is the need, in this multi-node system, to control the 'enable' inputs on the RS-485 transceivers; this is done because only one such device can be active on the network at any time.

The time-triggered nature of the shared-clock scheduler makes the controlled activation of the various transceivers straightforward.

---

## Overall strengths and weaknesses

- ☺ **A simple scheduler for distributed systems consisting of multiple 8051 microcontrollers.**
- ☺ **Easy to implement with low CPU and memory overheads.**
- ☺ **Twisted-pair cabling and differential signals make this more robust than RS-232-based alternatives.**
- ☹ UART supports byte-based communications only: data transfer between Master and Slaves (and vice versa) is limited to 0.5 bytes per clock tick
- ☹ Uses an important hardware resource (the UART)
- ☹ The hardware still has a very limited ability to detect errors: most error detection / correction must be carried out in software

## Example: Network with Max489 transceivers

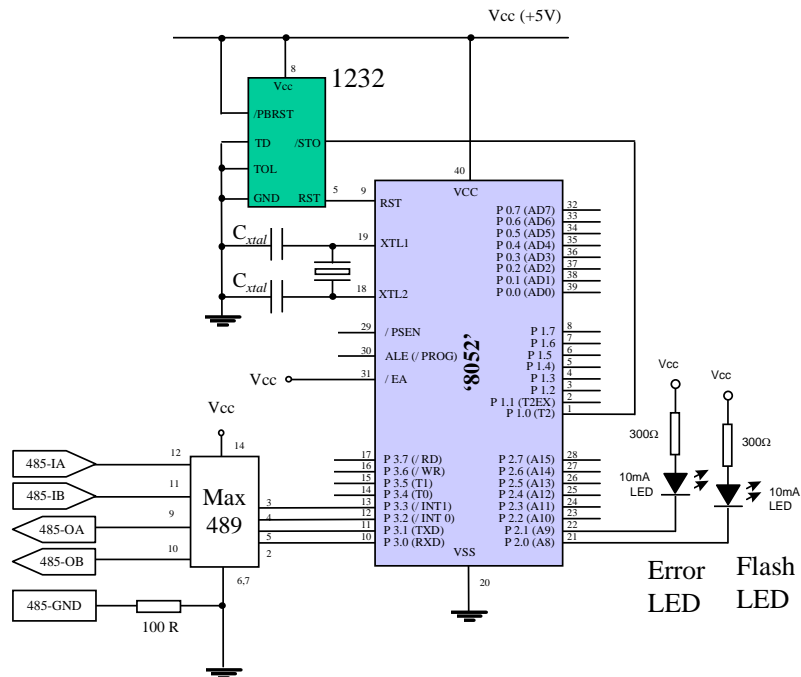

See PTES, Chapter 27, for code

---

## Preparations for the next seminar

Please read “PTTES” Chapter 28 before the next seminar.

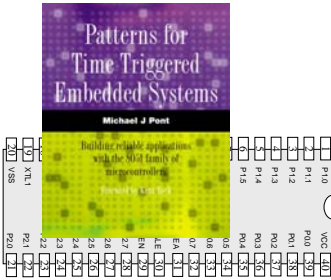



---

# Seminar 8:

## Linking processors using the Controller Area Network (CAN) bus

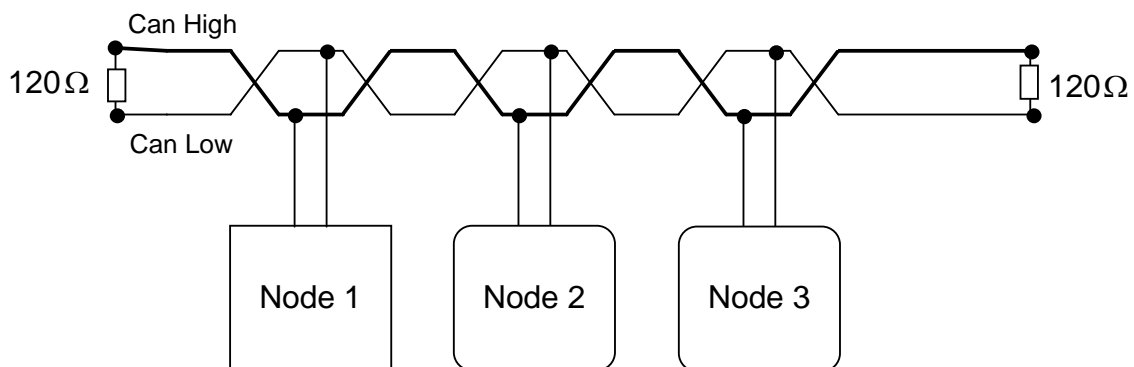

---

## Overview of this seminar

In this seminar, we will explain how you can schedule tasks on (and transfer data over) a network of two (or more) 8051 microcontrollers communicating using the CAN protocol.



---

## **PATTERN: SCC Scheduler**

We can summarise some of the features of CAN as follows:

- ☺ **CAN is message-based, and messages can be up to eight bytes in length. Used in a shared-clock scheduler, the data transfer between Master and Slaves (and vice versa) is up to 7 bytes per clock tick. This is adequate for most applications.**
- ☺ **The hardware has advanced error detection (and correction) facilities built in, further reducing the software load.**
- ☺ **CAN may be used for both 'local' and 'distributed' systems.**
  
- ☺ **A number of 8051 devices have on-chip support for CAN, allowing the protocol to be used with minimal overheads.**
- ☺ **Off-chip CAN transceivers can be used to allow use of this protocol with a huge range of devices.**

---

## What is CAN?

We begin our discussion of the Controller Area Network (CAN) protocol by highlighting some important features of this standard:

- CAN supports high-speed (1 Mbits/s) data transmission over short distances (40m) and low-speed (5 kbits/s) transmissions at lengths of up to 10,000m.
- CAN is message based. The data in each message may vary in length between 0 and 8 bytes. This data length is ideal for many embedded applications.
- The receipt of a message can be used to generate an interrupt. The interrupt will be generated only when a complete message (up to 8 bytes of data) has been received: this is unlike a UART (for example) which will respond to every character.
- CAN is a shared broadcast bus: all messages are sent to all nodes. However, each message has an identifier: this can be used to ‘filter’ messages. This means that - by using a ‘Full CAN’ controller (see below) - we can ensure that a particular node will only respond to ‘relevant’ messages: that is, messages with a particular ID.

This is very powerful. What this means in practice is, for example, that a Slave node can be set to ignore all messages directed from a different Slave to the Master.

- CAN is usually implemented on a simple, low-cost, two-wire differential serial bus system. Other physical media may be used, such as fibre optics (but this is comparatively rare).

- 
- The maximum number of nodes on a CAN bus is 32.
  - Messages can be given an individual priority. This means, for example, that ‘Tick messages’ can be given a higher priority than ‘Acknowledge messages’.
  - CAN is highly fault-tolerant, with powerful error detection and handling mechanisms built in to the controller.
  - Last but not least, microcontrollers with built-in CAN controllers are available from a range of companies. For example, 8051 devices with CAN controllers are available from Infineon (c505c, c515c), Philips (8xC592, 8xC598) and Dallas (80C390).

Overall, the CAN bus provides an excellent foundation for reliable distributed scheduled applications.

*We’ll now take a closer look at CAN...*

---

## CAN 1.0 vs. CAN 2.0

The CAN protocol comes in two versions: CAN 1.0 and CAN 2.0. CAN 2.0 is backwardly compatible with CAN 1.0, and most new controllers are CAN 2.0.

In addition, there are two parts to the CAN 2.0 standard: Part A and Part B. With CAN 1.0 and CAN 2.0A, identifiers must be 11-bits long. With CAN 2.0B identifiers can be 11-bits (a ‘standard’ identifier) or 29-bits (an ‘extended’ identifier).

The following basic compatibility rules apply:

- CAN 2.0B *active* controllers are able to send and receive both standard and extended messages.
- CAN 2.0B *passive* controllers are able to send and receive standard messages. In addition, they will discard (and ignore) extended frames. They will not generate an error when they ‘see’ extended messages.
- CAN 1.0 controllers generate bus errors when they see extended frames: they cannot be used on networks where extended identifiers are used.

---

## Basic CAN vs. Full CAN

There are two main classes of CAN controller available.

(Note that these classes are not covered by the standard, so there is some variation.)

The difference is that Full CAN controllers provide an acceptance filter that allows a node to ignore irrelevant messages.

This can be very useful.

---

## Which microcontrollers have support for CAN?

Available devices include:

- Dallas 80c390. Two on-chip CAN modules, each supporting CAN 2.0B.
- Infineon C505C. Supports CAN2.0B.
- Infineon C515C. Supports CAN2.0B.
- Philips 8xC591. Supports CAN2.0B.
- Philips 8x592. Supports CAN2.0A.
- Philips 8x598. Supports CAN2.0A.
- Temic T89C51CC01. Supports CAN2.0B.

---

## S-C scheduling over CAN

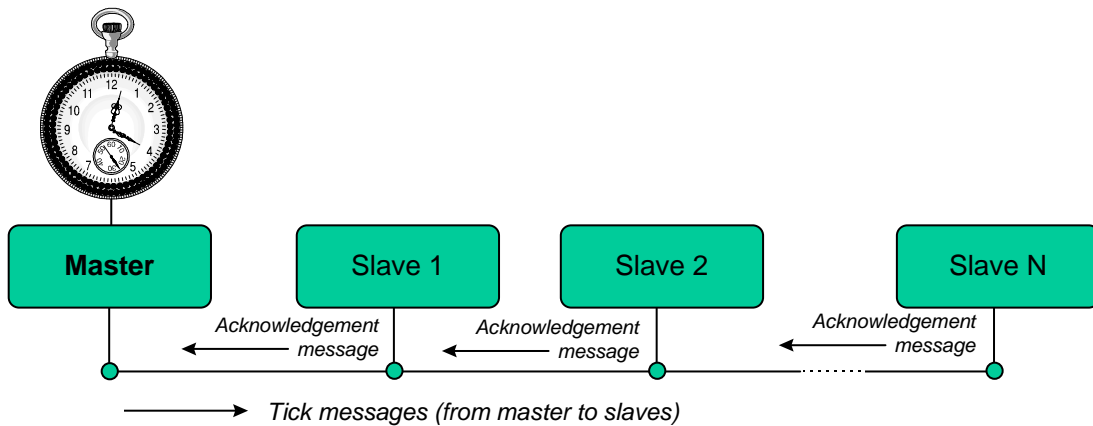

1. Timer overflow in the Master causes the scheduler 'Update' function to be invoked. This, in turn, causes a byte of data is sent (via the CAN bus) to all Slaves:

```
void MASTER_Update_T2(void) interrupt INTERRUPT_Timer_2_Overflow  
...
```

2. When these data have been received all Slaves generate an interrupt; this invokes the 'Update' function in the Slave schedulers. This, in turn, causes one Slave to send an 'Acknowledge' message back to the Master (again via the CAN bus).

```
void SLAVE_Update(void) interrupt INTERRUPT_CAN  
...
```

---

## The message structure - Tick messages

- Up to 31 Slave nodes (and one Master node) may be used in a CAN network. Each Slave is given a unique ID (0x01 to 0xFF).
- Each Tick Message from the Master is between one and eight bytes long; all of the bytes are sent in a single tick interval.
- In all messages, the first byte is the ID of the Slave to which the message is addressed; the remaining bytes (if any) are the message data.
- All Slaves generate interrupts in response to every Tick Message.

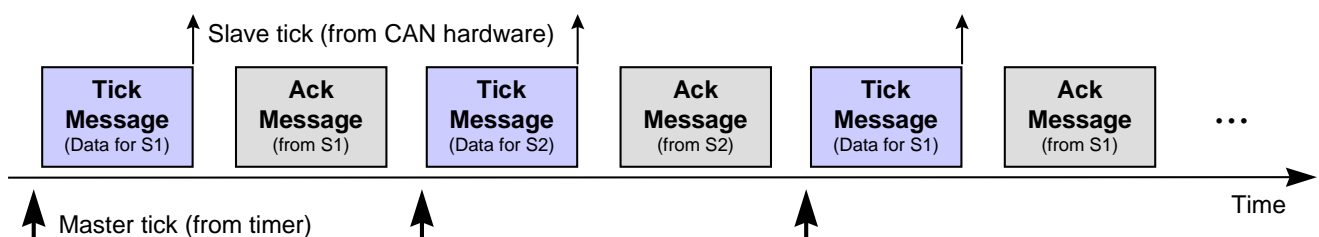



---

## The message structure - Ack messages

- **Only the Slave to which a Tick Message is addressed** will reply to the Master; this reply takes the form of an Acknowledge Message.
- Each Acknowledge Message from a Slave is between one and eight bytes long; all of the bytes are sent in the tick interval in which the Tick Message was received.
- The first byte of the Acknowledge Message is the ID of the Slave from which the message was sent; the remaining bytes (if any) are the message data.

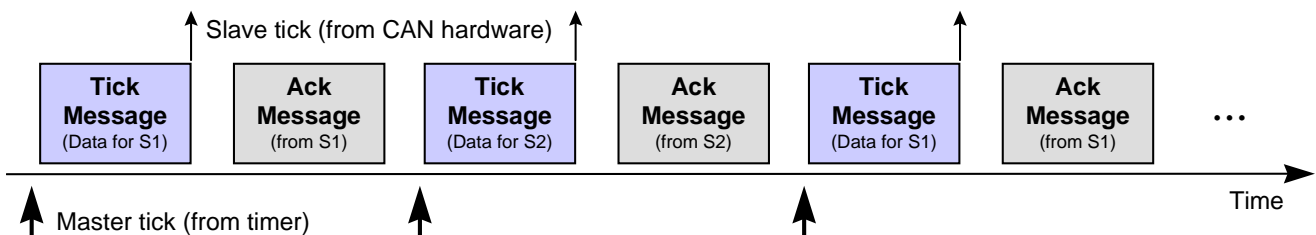

---

## Determining the required baud rate

Description	Size (bits)
Data	64
Start bit	1
Identifier bits	11
SRR bit	1
IDE bit	1
Identifier bits	18
RTR bit	1
Control bits	6
CRC bits	15
Stuff bits (maximum)	23
CRC delimiter	1
ACK slot	1
ACK delimiter	1
EOF bits	7
IFS bits	3
<b>TOTAL</b>	<b>154 bits / message</b>

We require two messages per tick: with 1 ms ticks, we require at least 308000 baud: allowing 350 000 baud gives a good margin for error. This is achievable with CAN, at distances up to around 100 metres. Should you require larger distances, the tick interval must either be lengthened, or repeater nodes should be added in the network at 100-metre intervals.

---

There is a delay between the timer on the Master and the CAN-based interrupt on the Slave:

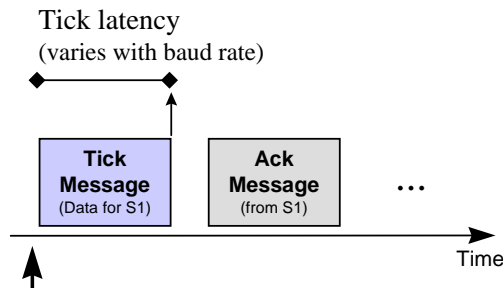

**In the absence of network errors**, this delay is fixed, and derives largely from the time taken to transmit a message via the CAN bus; that is, it varies with the baud rate.

At a baud rate of 350 kbits/second, the tick is approx. 0.5 ms.

If precise synchronisation of Master and Slave processing is required, then please note that:

- All the Slaves are - within the limits of measurement - precisely in step.
- To bring the Master in step with the Slaves, it is necessary only to add a short delay in the Master 'Update' function.

---

## Transceivers for distributed networks

The Philips PCA82c250 is a popular transceiver.

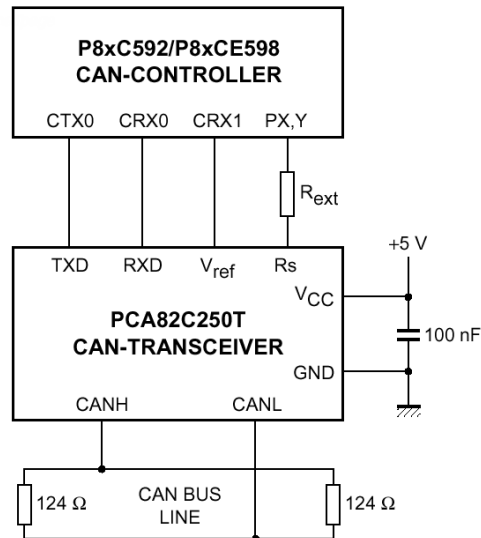

---

## Node wiring for distributed networks

The most common means of linking together CAN nodes is through the use of a two-wire, twisted pair (like RS-485).

In the CAN bus, the two signal lines are termed ‘CAN High’ and ‘CAN Low’. In the quiescent state, both lines sit at 2.5V. A ‘1’ is transmitted by raising the voltage of the High line above that of Low line: this is termed a ‘dominant’ bit. A ‘0’ is represented by raising the voltage of the Low line above that of the High line: this is termed a ‘recessive’ bit.

Using twisted-pair wiring, the differential CAN inputs successfully cancel out noise. In addition, the CAN networks connected in this way continue to function even when one of the lines is severed.

Note that, as with the RS-485 cabling, a  $120\Omega$  terminating resistor is connected at each end of the bus:

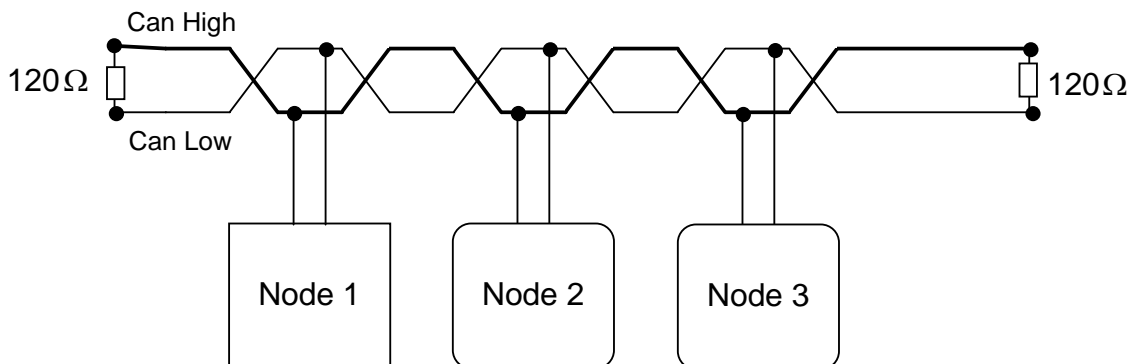

---

## Hardware and wiring for local networks

Use of a 'local' CAN network does not require the use of transceiver chips.

In most cases, simply connecting together the Tx and Rx lines from a number of CAN-based microcontrollers will allow you to link the devices.

A better solution (proposed by Barrenscheen, 1996) is based on a wired-OR structure.

As no CAN transceiver is used, the maximum wire length is limited to a maximum of one metre, and disturbances due to noise can occur.

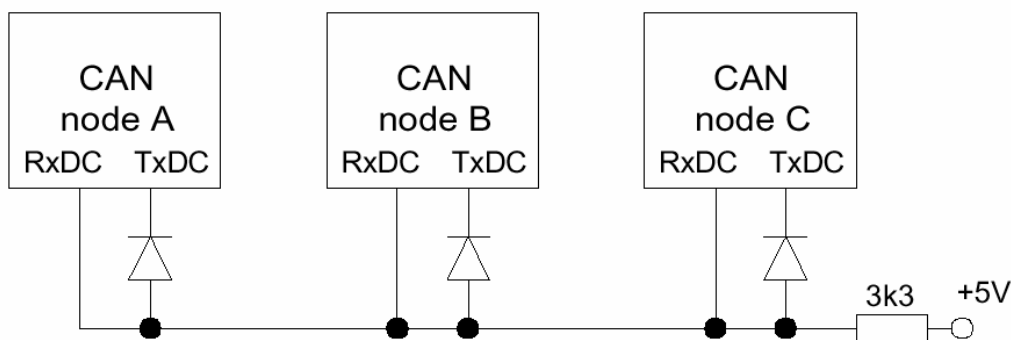

---

## Software for the shared-clock CAN scheduler

One important difference between the CAN-based scheduler presented here and those that were discussed previously chapters is the error-handling mechanism.

Here, if a Slave fails, then - rather than restarting the whole network - we attempt to start the corresponding backup unit.

The strengths and weaknesses of this approach are as follows:

- ☺ **It allows full use to be made of backup nodes.**
- ☺ **In most circumstances it takes comparatively little time to engage the backup unit.**
- ☹ The underlying coding is more complicated than the other alternatives discussed in this course.

---

## Overall strengths and weaknesses

- ☺ **CAN is message-based, and messages can be up to eight bytes in length. Used in a shared-clock scheduler, the data transfer between Master and Slaves (and vice versa) is up to 7 bytes per clock tick. This is more than adequate for the great majority of applications.**
- ☺ **A number of 8051 devices have on-chip support for CAN, allowing the protocol to be used with minimal overheads.**
- ☺ **The hardware has advanced error detection (and correction) facilities built in, further reducing the software load**
- ☺ **CAN may be used for both 'local' and 'distributed' systems.**
- ☹ **8051 devices with CAN support tend to be more expensive than 'standard' 8051s.**



---

## **Example: Creating a CAN-based scheduler using the Infineon C515c**

This example illustrates the use of the Infineon c515C microcontroller. This popular device has on-chip CAN hardware.

The code may be used in either a distributed or local network, with the hardware discussed above.

**See PTTES, Chapter 28 for complete code listings**

---

## Master Software

```
void SCC_A_MASTER_Init_T2_CAN(void)
{
    tByte i;
    tByte Message;
    tByte Slave_index;

    EA = 0;    /* No interrupts (yet) */

    SCC_A_MASTER_Watchdog_Init(); /* Start the watchdog */

    Network_error_pin = NO_NETWORK_ERROR;

    for (i = 0; i < SCH_MAX_TASKS; i++)
    {
        SCH_Delete_Task(i); /* Clear the task array */
    }

    /* SCH_Delete_Task() will generate an error code,
       because the task array is empty.
       -> reset the global error variable. */
    Error_code_G = 0;

    /* We allow any combination of ID numbers in slaves */
    for (Slave_index = 0; Slave_index < NUMBER_OF_SLAVES; Slave_index++)
    {
        Slave_reset_attempts_G[Slave_index] = 0;
        Current_Slave_IDS_G[Slave_index] = MAIN_SLAVE_IDS[Slave_index];
    }

    /* Get ready to send first tick message */
    First_ack_G = 1;
    Slave_index_G = 0;

    /* ----- Set up the CAN link (begin) ----- */

    /* ----- SYSCON Register -----
       The access to XRAM and CAN controller is enabled.
       The signals !RD and !WR are not activated during accesses
       to the XRAM/CAN controller.
       ALE generation is enabled. */
    SYSCON = 0x20;

    /* ----- CAN Control/Status Register -----
       Start to init the CAN module. */
    CAN_cr = 0x41; /* INIT and CCE */
}
```

---

```

/* ----- Bit Timing Register -----
   Baudrate = 333.333 kbaud
   - Need 308+ kbaud plus for 1ms ticks, 8 data bytes
   - See text for details

   There are 5 time quanta before sample point
   There are 4 time quanta after sample point
   The (re)synchronization jump width is 2 time quanta. */
CAN_btr1 = 0x34;      /* Bit Timing Register */
CAN_btr0 = 0x42;

CAN_gms1 = 0xFF;     /* Global Mask Short Register 1 */
CAN_gms0 = 0xFF;     /* Global Mask Short Register 0 */

CAN_ugml1 = 0xFF;    /* Upper Global Mask Long Register 1 */
CAN_ugml0 = 0xFF;    /* Upper Global Mask Long Register 0 */

CAN_lgml1 = 0xF8;    /* Lower Global Mask Long Register 1 */
CAN_lgml0 = 0xFF;    /* Lower Global Mask Long Register 0 */

/* --- Configure the 'Tick' Message Object --- */
/* 'Message Object 1' is valid */
CAN_messages[0].MCR1 = 0x55;    /* Message Control Register 1 */
CAN_messages[0].MCR0 = 0x95;    /* Message Control Register 0 */

/* Message direction is transmit
   Extended 29-bit identifier
   These have ID 0x000000 and 5 valid data bytes. */
CAN_messages[0].MCFG = 0x5C;    /* Message Config Reg */

CAN_messages[0].UAR1 = 0x00;    /* Upper Arbit. Reg. 1 */
CAN_messages[0].UAR0 = 0x00;    /* Upper Arbit. Reg. 0 */
CAN_messages[0].LAR1 = 0x00;    /* Lower Arbit. Reg. 1 */
CAN_messages[0].LAR0 = 0x00;    /* Lower Arbit. Reg. 0 */

CAN_messages[0].Data[0] = 0x00; /* Data byte 0 */
CAN_messages[0].Data[1] = 0x00; /* Data byte 1 */
CAN_messages[0].Data[2] = 0x00; /* Data byte 2 */
CAN_messages[0].Data[3] = 0x00; /* Data byte 3 */
CAN_messages[0].Data[4] = 0x00; /* Data byte 4 */

```

---

```

/* --- Configure the 'Ack' Message Object --- */

/* 'Message Object 2' is valid
   NOTE: Object 2 receives *ALL* ack messages. */
CAN_messages[1].MCR1 = 0x55; /* Message Control Register 1 */
CAN_messages[1].MCR0 = 0x95; /* Message Control Register 0 */

/* Message direction is receive
   Extended 29-bit identifier
   These all have ID: 0x000000FF (5 valid data bytes) */
CAN_messages[1].MCFG = 0x04; /* Message Config Reg */

CAN_messages[1].UAR1 = 0x00; /* Upper Arbit. Reg. 1 */
CAN_messages[1].UAR0 = 0x00; /* Upper Arbit. Reg. 0 */
CAN_messages[1].LAR1 = 0xF8; /* Lower Arbit. Reg. 1 */
CAN_messages[1].LAR0 = 0x07; /* Lower Arbit. Reg. 0 */

/* Configure remaining message objects - none is valid */
for (Message = 2; Message <= 14; ++Message)
{
    CAN_messages[Message].MCR1 = 0x55; /* Message Control Reg 1 */
    CAN_messages[Message].MCR0 = 0x55; /* Message Control Reg 0 */
}

/* ----- CAN Control Register ----- */
/* Reset CCE and INIT */
CAN_cr = 0x00;

/* ----- Set up the CAN link (end) ----- */

```

---

```

/* ----- Set up Timer 2 (begin) ----- */
/* 80c515c, 10 MHz
   Timer 2 is set to overflow every 6 ms - see text
   Mode 1 = Timerfunction */
/* Prescaler: Fcpu/12 */
T2PS = 1;

/* Mode 0 = auto-reload upon timer overflow
   Preset the timer register with autoreload value
   NOTE: Timing is same as standard (8052) T2 timing
   - if T2PS = 1 (otherwise twice as fast as 8052) */
TL2 = 0x78;
TH2 = 0xEC;

/* Mode 0 for all channels */
T2CON |= 0x11;

/* Timer 2 overflow interrupt is enabled */
ET2 = 1;
/* Timer 2 external reload interrupt is disabled */
EXEN2 = 0;

/* Compare/capture Channel 0 */
/* Disabled */
/* Compare Register CRC on: 0x0000; */
CRCL = 0x78;
CRCH = 0xEC;

/* CC0/ext3 interrupt is disabled */
EX3 = 0;

/* Compare/capture Channel 1-3 */
/* Disabled */
CCL1 = 0x00;
CCH1 = 0x00;
CCL2 = 0x00;
CCH2 = 0x00;
CCL3 = 0x00;
CCH3 = 0x00;

/* Interrupts Channel 1-3 are disabled */
EX4 = 0;
EX5 = 0;
EX6 = 0;

/* All above mentioned modes for Channel 0 to Channel 3 */
CCEN = 0x00;
/* ----- Set up Timer 2 (end) ----- */
}

```

---

```
void SCC_A_MASTER_Start(void)
{
    tByte Num_active_slaves;
    tByte i;
    bit Slave_replied_correctly;
    tByte Slave_index, Slave_ID;

    /* Refresh the watchdog */
    SCC_A_MASTER_Watchdog_Refresh();

    /* Place system in 'safe state' */
    SCC_A_MASTER_Enter_Safe_State();

    /* Report error as we wait to start */
    Network_error_pin = NETWORK_ERROR;

    Error_code_G = ERROR_SCH_WAITING_FOR_SLAVE_TO_ACK;
    SCH_Report_Status(); /* Sch not yet running - do this manually */

    /* Pause here (300 ms), to time-out all the slaves
       (This is the means by which we sync the network) */
    for (i = 0; i < 10; i++)
    {
        Hardware_Delay_T0(30);
        SCC_A_MASTER_Watchdog_Refresh();
    }

    /* Currently disconnected from all slaves */
    Num_active_slaves = 0;
}
```

---

```

/* After the initial (long) delay, all slaves will have timed out.
   All operational slaves will now be in the 'READY TO START' state
   Send them a 'slave id' message to get them started. */
Slave_index = 0;
do {
    /* Refresh the watchdog */
    SCC_A_MASTER_Watchdog_Refresh();

    /* Find the slave ID for this slave */
    Slave_ID = (tByte) Current_Slave_IDs_G[Slave_index];

    Slave_replied_correctly = SCC_A_MASTER_Start_Slave(Slave_ID);

    if (Slave_replied_correctly)
    {
        Num_active_slaves++;
        Slave_index++;
    }
    else
    {
        /* Slave did not reply correctly
           - try to switch to backup device (if available) */
        if (Current_Slave_IDs_G[Slave_index] !=
            BACKUP_SLAVE_IDs[Slave_index])
        {
            /* A backup is available: switch to it and re-try */
            Current_Slave_IDs_G[Slave_index]
                = BACKUP_SLAVE_IDs[Slave_index];
        }
        else
        {
            /* No backup available (or backup failed too)
               - have to continue */
            Slave_index++;
        }
    }
} while (Slave_index < NUMBER_OF_SLAVES);

```

---

```
/* DEAL WITH CASE OF MISSING SLAVE(S) HERE ... */
if (Num_active_slaves < NUMBER_OF_SLAVES)
{
    /* 1 or more slaves have not replied.
       In some circumstances you may wish to abort here,
       or try to reconfigure the network.

       Simplest solution is to display an error and carry on
       (that is what we do here). */
    Error_code_G = ERROR_SCH_ONE_OR_MORE_SLAVES_DID_NOT_START;
    Network_error_pin = NETWORK_ERROR;
}
else
{
    Error_code_G = 0;
    Network_error_pin = NO_NETWORK_ERROR;
}

/* Start the scheduler */
IRCON = 0;
EA = 1;
}
```



---

```

void SCC_A_MASTER_Update_T2(void) interrupt INTERRUPT_Timer_2_Overflow
{
    tByte Index;
    tByte Previous_slave_index;
    bit Slave_replied_correctly;

    TF2 = 0;  /* Must clear this.  */

    /* Refresh the watchdog */
    SCC_A_MASTER_Watchdog_Refresh();

    /* Default */
    Network_error_pin = NO_NETWORK_ERROR;

    /* Keep track of the current slave
       (First value of "prev slave" is 0) */
    Previous_slave_index = Slave_index_G

    if (++Slave_index_G >= NUMBER_OF_SLAVES)
        {
            Slave_index_G = 0;
        }

    /* Check that the approp slave replied to the last message.
       (If it did, store the data sent by this slave) */
    if (SCC_A_MASTER_Process_Ack(Previous_slave_index) == RETURN_ERROR)
        {
            Error_code_G = ERROR_SCH_LOST_SLAVE;
            Network_error_pin = NETWORK_ERROR;

            /* If we have lost contact with a slave, we attempt to
               switch to a backup device (if one is available) */
            if (Current_Slave_IDs_G[Slave_index_G] !=
                BACKUP_SLAVE_IDs[Slave_index_G])
                {
                    /* A backup is available: switch to it and re-try */
                    Current_Slave_IDs_G[Slave_index_G] =
                        BACKUP_SLAVE_IDs[Slave_index_G];
                }
            else
                {
                    /* There is no backup available (or we are already using it).
                       Try main device again. */
                    Current_Slave_IDs_G[Slave_index_G] =
                        MAIN_SLAVE_IDs[Slave_index_G];
                }
        }
}

```

---

```

    /* Try to connect to the slave */
    Slave_replied_correctly =
    SCC_A_MASTER_Start_Slave(Current_Slave_IDs_G[Slave_index_G]);

    if (!Slave_replied_correctly)
    {
        /* No backup available (or it failed too) - we shut down
           (OTHER ACTIONS MAY BE MORE APPROPRIATE IN YOUR SYSTEM!) */
        SCC_A_MASTER_Shut_Down_the_Network();
    }
}

/* Send 'tick' message to all connected slaves
   (sends one data byte to the current slave). */
SCC_A_MASTER_Send_Tick_Message(Slave_index_G);

/* Check the last error codes on the CAN bus */
if ((CAN_sr & 0x07) != 0)
{
    Error_code_G = ERROR_SCH_CAN_BUS_ERROR;
    Network_error_pin = NETWORK_ERROR;

    /* See Infineon C515C manual for error code details */
    CAN_error_pin0 = ((CAN_sr & 0x01) == 0);
    CAN_error_pin1 = ((CAN_sr & 0x02) == 0);
    CAN_error_pin2 = ((CAN_sr & 0x04) == 0);
}
else
{
    CAN_error_pin0 = 1;
    CAN_error_pin1 = 1;
    CAN_error_pin2 = 1;
}

```

---

```

/* NOTE: calculations are in *TICKS* (not milliseconds) */
for (Index = 0; Index < SCH_MAX_TASKS; Index++)
{
    /* Check if there is a task at this location */
    if (SCH_tasks_G[Index].pTask)
    {
        if (SCH_tasks_G[Index].Delay == 0)
        {
            /* The task is due to run */
            SCH_tasks_G[Index].RunMe += 1; /* Inc RunMe */

            if (SCH_tasks_G[Index].Period)
            {
                /* Schedule periodic tasks to run again */
                SCH_tasks_G[Index].Delay = SCH_tasks_G[Index].Period;
            }
        }
        else
        {
            /* Not yet ready to run: just decrement the delay */
            SCH_tasks_G[Index].Delay -= 1;
        }
    }
}

```

---

```
void SCC_A_MASTER_Send_Tick_Message(const tByte SLAVE_INDEX)
{
    /* Find the slave ID for this slave
       ALL SLAVES MUST HAVE A UNIQUE (non-zero) ID! */
    tByte Slave_ID = (tByte) Current_Slave_IDs_G[SLAVE_INDEX];
    CAN_messages[0].Data[0] = Slave_ID;

    /* Fill the data fields */
    CAN_messages[0].Data[1] = Tick_message_data_G[SLAVE_INDEX][0];
    CAN_messages[0].Data[2] = Tick_message_data_G[SLAVE_INDEX][1];
    CAN_messages[0].Data[3] = Tick_message_data_G[SLAVE_INDEX][2];
    CAN_messages[0].Data[4] = Tick_message_data_G[SLAVE_INDEX][3];

    /* Send the message on the CAN bus */
    CAN_messages[0].MCR1 = 0xE7; /* TXRQ, reset CPUUPD */
}
```

---

```

bit SCC_A_MASTER_Process_Ack(const tByte SLAVE_INDEX)
{
    tByte Ack_ID, Slave_ID;

    /* First time this is called there is no Ack message to check
       - we simply return 'OK'. */
    if (First_ack_G)
    {
        First_ack_G = 0;
        return RETURN_NORMAL;
    }

    if ((CAN_messages[1].MCR1 & 0x03) == 0x02)    /* if NEWDAT */
    {
        /* An ack message was received
           -> extract the data */
        Ack_ID = CAN_messages[1].Data[0];    /* Get data byte 0 */

        Ack_message_data_G[SLAVE_INDEX][0] = CAN_messages[1].Data[1];
        Ack_message_data_G[SLAVE_INDEX][1] = CAN_messages[1].Data[2];
        Ack_message_data_G[SLAVE_INDEX][2] = CAN_messages[1].Data[3];
        Ack_message_data_G[SLAVE_INDEX][3] = CAN_messages[1].Data[4];

        CAN_messages[1].MCR0 = 0xfd;    /* reset NEWDAT, INTPND */
        CAN_messages[1].MCR1 = 0xfd;

        /* Find the slave ID for this slave */
        Slave_ID = (tByte) Current_Slave_IDs_G[SLAVE_INDEX];

        if (Ack_ID == Slave_ID)
        {
            return RETURN_NORMAL;
        }
    }

    /* No message, or ID incorrect */
    return RETURN_ERROR;
}

```

---

```
void SCC_A_MASTER_Shut_Down_the_Network(void)
{
    EA = 0;

    while(1)
    {
        SCC_A_MASTER_Watchdog_Refresh();
    }
}
```

```
void SCC_A_MASTER_Enter_Safe_State(void)
{
    /* USER DEFINED - Edit as required */

    TRAFFIC_LIGHTS_Display_Safe_Output();
}
```

---

## Slave Software

```
void SCC_A_SLAVE_Init_CAN(void)
{
    tByte i;
    tByte Message;

    /* Sort out the tasks */
    for (i = 0; i < SCH_MAX_TASKS; i++)
    {
        SCH_Delete_Task(i);
    }

    /* SCH_Delete_Task() will generate an error code,
       because the task array is empty.
       -> reset the global error variable. */
    Error_code_G = 0;

    /* Set the network error pin (reset when tick message received) */
    Network_error_pin = NETWORK_ERROR;

    /* ----- SYSCON Register
       The access to XRAM and CAN controller is enabled.
       The signals !RD and !WR are not activated during accesses
       to the XRAM/CAN controller.
       ALE generation is enabled. */
    SYSCON = 0x20;

    /* ----- CAN Control/Status Register ----- */
    CAN_cr = 0x41; /* INIT and CCE */

    /* ----- Bit Timing Register -----
       Baudrate = 333.333 kbaud
       - Need 308+ kbaud plus for 1ms ticks, 8 data bytes
       - See text for details

       There are 5 time quanta before sample point
       There are 4 time quanta after sample point
       The (re)synchronization jump width is 2 time quanta. */
    CAN_btr1 = 0x34; /* Bit Timing Register */
    CAN_btr0 = 0x42;
    CAN_gms1 = 0xFF; /* Global Mask Short Register 1 */
    CAN_gms0 = 0xFF; /* Global Mask Short Register 0 */
    CAN_ugml1 = 0xFF; /* Upper Global Mask Long Register 1 */
    CAN_ugml0 = 0xFF; /* Upper Global Mask Long Register 0 */
    CAN_lgml1 = 0xF8; /* Lower Global Mask Long Register 1 */
    CAN_lgml0 = 0xFF; /* Lower Global Mask Long Register 0 */
```

---

```

/* ----- Configure 'Tick' Message Object */
/* Message object 1 is valid */
/* Enable receive interrupt */
CAN_messages[0].MCR1 = 0x55; /* Message Ctrl. Reg. 1 */
CAN_messages[0].MCR0 = 0x99; /* Message Ctrl. Reg. 0 */

/* message direction is receive */
/* extended 29-bit identifier */
CAN_messages[0].MCFG = 0x04; /* Message Config. Reg. */

CAN_messages[0].UAR1 = 0x00; /* Upper Arbit. Reg. 1 */
CAN_messages[0].UAR0 = 0x00; /* Upper Arbit. Reg. 0 */
CAN_messages[0].LAR1 = 0x00; /* Lower Arbit. Reg. 1 */
CAN_messages[0].LAR0 = 0x00; /* Lower Arbit. Reg. 0 */

/* ----- Configure 'Ack' Message Object */
CAN_messages[1].MCR1 = 0x55; /* Message Ctrl. Reg. 1 */
CAN_messages[1].MCR0 = 0x95; /* Message Ctrl. Reg. 0 */

/* Message direction is transmit */
/* Extended 29-bit identifier; 5 valid data bytes */
CAN_messages[1].MCFG = 0x5C; /* Message Config. Reg. */
CAN_messages[1].UAR1 = 0x00; /* Upper Arbit. Reg. 1 */
CAN_messages[1].UAR0 = 0x00; /* Upper Arbit. Reg. 0 */
CAN_messages[1].LAR1 = 0xF8; /* Lower Arbit. Reg. 1 */
CAN_messages[1].LAR0 = 0x07; /* Lower Arbit. Reg. 0 */
CAN_messages[1].Data[0] = 0x00; /* Data byte 0 */
CAN_messages[1].Data[1] = 0x00; /* Data byte 1 */
CAN_messages[1].Data[2] = 0x00; /* Data byte 2 */
CAN_messages[1].Data[3] = 0x00; /* Data byte 3 */
CAN_messages[1].Data[4] = 0x00; /* Data byte 4 */

/* ----- Configure other objects ----- */
/* Configure remaining message objects (2-14) - none is valid */
for (Message = 2; Message <= 14; ++Message)
{
    CAN_messages[Message].MCR1 = 0x55; /* Message Ctrl. Reg. 1 */
    CAN_messages[Message].MCR0 = 0x55; /* Message Ctrl. Reg. 0 */
}

/* ----- CAN Ctrl. Reg. ----- */
/* Reset CCE and INIT */
/* Enable interrupt generation from CAN Modul */
/* Enable CAN-interrupt of Controller */
CAN_cr = 0x02;
IEN2 |= 0x02;

SCC_A_SLAVE_Watchdog_Init(); /* Start the watchdog */
}

```



---

```

void SCC_A_SLAVE_Start(void)
{
    tByte Tick_00, Tick_ID;
    bit Start_slave;

    /* Disable interrupts */
    EA = 0;

    /* We can be at this point because:
    1. The network has just been powered up
    2. An error has occurred in the Master, and it is not gen. ticks
    3. The network has been damaged -> no ticks are being recv

    Try to make sure the system is in a safe state...
    NOTE: Interrupts are disabled here!! */
    SCC_A_SLAVE_Enter_Safe_State();

    Start_slave = 0;
    Error_code_G = ERROR_SCH_WAITING_FOR_START_COMMAND_FROM_MASTER;
    SCH_Report_Status(); /* Sch not yet running - do this manually */

    /* Now wait (indefinitely) for approp signal from the Master */
    do {
        /* Wait for 'Slave ID' message to be received */
        do {
            SCC_A_SLAVE_Watchdog_Refresh(); /* Must feed watchdog */
        } while ((CAN_messages[0].MCR1 & 0x03) != 0x02);

        /* Got a message - extract the data */
        if ((CAN_messages[0].MCR1 & 0x0c) == 0x08) /* if MSGLST set */
        {
            /* Ignore lost message */
            CAN_messages[0].MCR1 = 0xf7; /* reset MSGLST */
        }

        Tick_00 = (tByte) CAN_messages[0].Data[0]; /* Get Data 0 */
        Tick_ID = (tByte) CAN_messages[0].Data[1]; /* Get Data 1 */

        CAN_messages[0].MCR0 = 0xfd; /* reset NEWDAT, INTPND */
        CAN_messages[0].MCR1 = 0xfd;
    }

```

---

```
if ((Tick_00 == 0x00) && (Tick_ID == SLAVE_ID))
{
    /* Message is correct */
    Start_slave = 1;

    /* Send ack */
    CAN_messages[1].Data[0] = 0x00;      /* Set data byte 0 */
    CAN_messages[1].Data[1] = SLAVE_ID; /* Set data byte 1 */
    CAN_messages[1].MCR1 = 0xE7;        /* Send message */
}
else
{
    /* Not yet received correct message - wait */
    Start_slave = 0;
}
} while (!Start_slave);

/* Start the scheduler */
IRCON = 0;
EA = 1;
}
```

---

```

void SCC_A_SLAVE_Update(void) interrupt INTERRUPT_CAN_c515c
{
    tByte Index;

    /* Reset this when tick is received */
    Network_error_pin = NO_NETWORK_ERROR;

    /* Check tick data - send ack if necessary
    NOTE: 'START' message will only be sent after a 'time out' */
    if (SCC_A_SLAVE_Process_Tick_Message() == SLAVE_ID)
    {
        SCC_A_SLAVE_Send_Ack_Message_To_Master();

        /* Feed the watchdog ONLY when a *relevant* message is received
        (Noise on the bus, etc, will not stop the watchdog)
        START messages will NOT refresh the slave.
        - Must talk to every slave at suitable intervals. */
        SCC_A_SLAVE_Watchdog_Refresh();
    }

    /* Check the last error codes on the CAN bus */
    if ((CAN_sr & 0x07) != 0)
    {
        Error_code_G = ERROR_SCH_CAN_BUS_ERROR;
        Network_error_pin = NETWORK_ERROR;

        /* See Infineon c515c manual for error code details */
        CAN_error_pin0 = ((CAN_sr & 0x01) == 0);
        CAN_error_pin1 = ((CAN_sr & 0x02) == 0);
        CAN_error_pin2 = ((CAN_sr & 0x04) == 0);
    }
    else
    {
        CAN_error_pin0 = 1;
        CAN_error_pin1 = 1;
        CAN_error_pin2 = 1;
    }
}

```

---

```

/* NOTE: calculations are in *TICKS* (not milliseconds) */
for (Index = 0; Index < SCH_MAX_TASKS; Index++)
{
    /* Check if there is a task at this location */
    if (SCH_tasks_G[Index].pTask)
    {
        if (SCH_tasks_G[Index].Delay == 0)
        {
            /* The task is due to run */
            SCH_tasks_G[Task_index].RunMe += 1; /* Inc RunMe */

            if (SCH_tasks_G[Task_index].Period)
            {
                /* Schedule periodic tasks to run again */
                SCH_tasks_G[Task_index].Delay =
                    SCH_tasks_G[Task_index].Period;
            }
        }
        else
        {
            /* Not yet ready to run: just decrement the delay */
            SCH_tasks_G[Index].Delay -= 1;
        }
    }
}

```

---

```

tByte SCC_A_SLAVE_Process_Tick_Message(void)
{
    tByte Tick_ID;

    if ((CAN_messages[0].MCR1 & 0x0c) == 0x08) /* If MSGLST set */
    {
        /* The CAN controller has stored a new
           message into this object, while NEWDAT was still set,
           i.e. the previously stored message is lost.
           We simply IGNORE this here and reset the flag. */
        CAN_messages[0].MCR1 = 0xf7; /* reset MSGLST */
    }

    /* The first byte is the ID of the slave
       for which the data are intended. */
    Tick_ID = CAN_messages[0].Data[0]; /* Get Slave ID */

    if (Tick_ID == SLAVE_ID)
    {
        /* Only if there is a match do we need to copy these fields */
        Tick_message_data_G[0] = CAN_messages[0].Data[1];
        Tick_message_data_G[1] = CAN_messages[0].Data[2];
        Tick_message_data_G[2] = CAN_messages[0].Data[3];
        Tick_message_data_G[3] = CAN_messages[0].Data[4];
    }

    CAN_messages[0].MCR0 = 0xfd; /* reset NEWDAT, INTPND */
    CAN_messages[0].MCR1 = 0xfd;

    return Tick_ID;
}

void SCC_A_SLAVE_Send_Ack_Message_To_Master(void)
{
    /* First byte of message must be slave ID */
    CAN_messages[1].Data[0] = SLAVE_ID; /* data byte 0 */

    CAN_messages[1].Data[1] = Ack_message_data_G[0];
    CAN_messages[1].Data[2] = Ack_message_data_G[1];
    CAN_messages[1].Data[3] = Ack_message_data_G[2];
    CAN_messages[1].Data[4] = Ack_message_data_G[3];

    /* Send the message on the CAN bus */
    CAN_messages[1].MCR1 = 0xE7; /* TXRQ, reset CPUUPD */
}

```

---

## What about CAN without on-chip hardware support?

### Master node using Microchip MCP2510 CAN transceiver

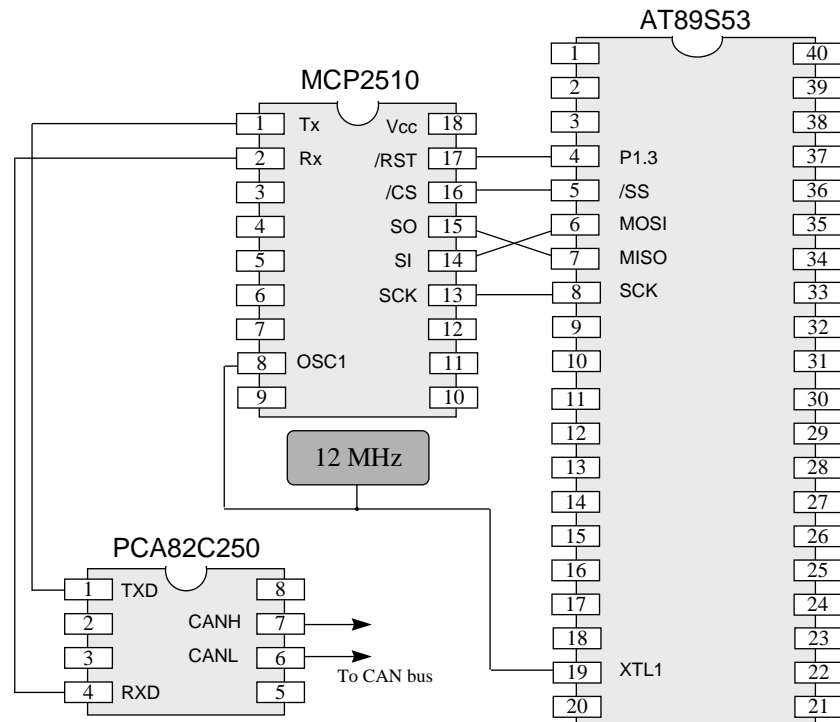

## Slave node using Microchip MCP2510 CAN transceiver

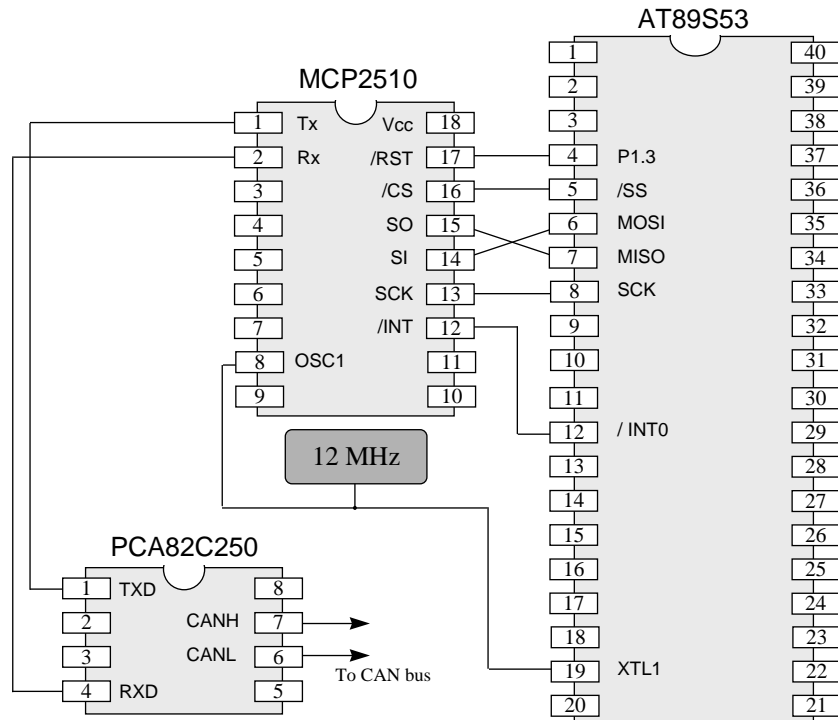

---

## Preparations for the next seminar

Please read PTTES Chapter 35 before the next seminar.

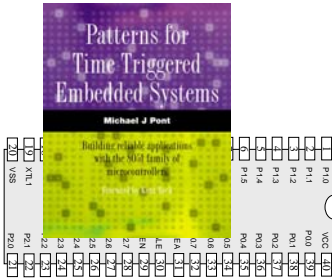



---

# Seminar 9:

## Applying “Proportional Integral Differential” (PID) control

$$u(k) = u(k-1) + K \left[ \left( 1 + \frac{T}{T_i} + \frac{T_D}{T} \right) e(k) - \left( 1 + 2 \frac{T_D}{T} \right) e(k-1) + \frac{T_D}{T} e(k-2) \right]$$

$$u(k) = u(k-1) + K \left[ \left( 1 + \frac{T}{T_i} + \frac{T_D}{T} \right) e(k) - \left( 1 + 2 \frac{T_D}{T} \right) e(k-1) + \frac{T_D}{T} e(k-2) \right]$$

$$u(k) = u(k-1) + K \left[ \left( 1 + \frac{T}{T_i} + \frac{T_D}{T} \right) e(k) - \left( 1 + 2 \frac{T_D}{T} \right) e(k-1) + \frac{T_D}{T} e(k-2) \right]$$

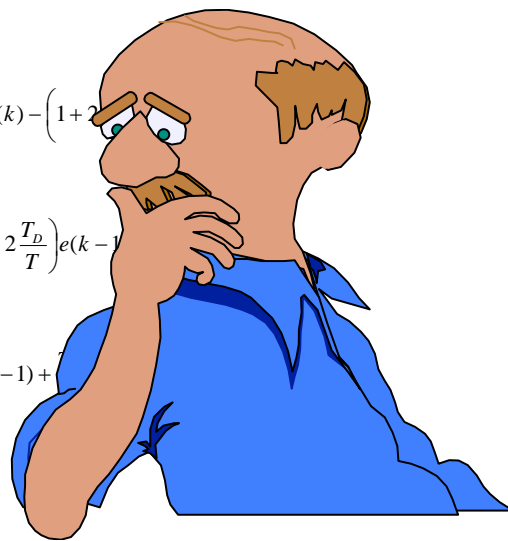

---

## Overview of this seminar

- The focus of this seminar is on Proportional-Integral-Differential (PID) control.
- PID is both simple and effective: as a consequence it is the most widely used control algorithm.
- The focus here will be on techniques for designing and implementing PID controllers for use in embedded applications.

---

## Why do we need closed-loop control?

Suppose we wish to control the speed of a DC motor, used as part of an air-traffic control application.

To control this speed, we will assume that we have decided to change the applied motor voltage using a DAC.

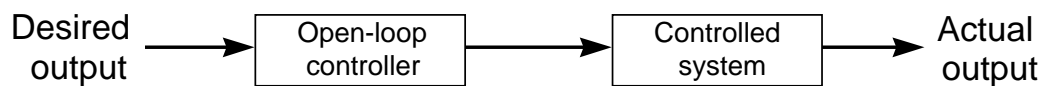

In an ideal world, this type of open-loop control system would be easy to design: we would simply have a look-up table linking the required motor speed to the required output parameters.

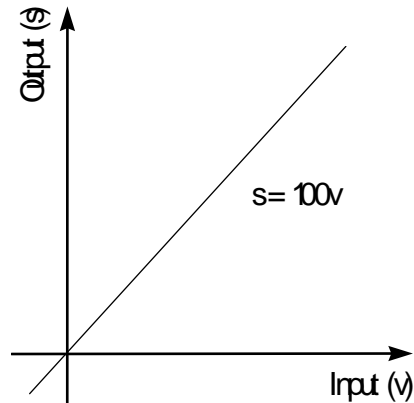

Radar rotation speed (RPM)	DAC setting (8-bit)
0	0
2	51
4	102
6	153
8	204
10	255

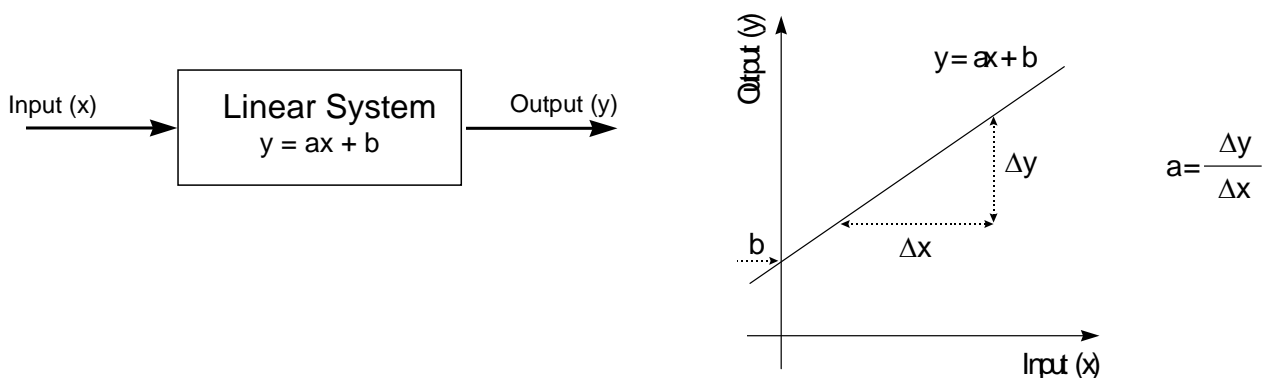

---

Unfortunately, such linearity is very rare in practical systems.

For example:

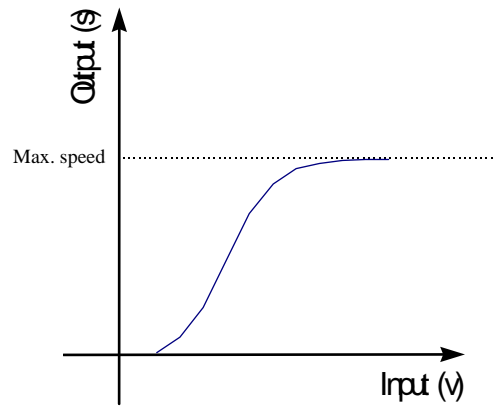

However, we can still create a table:

Radar rotation speed (RPM)	DAC setting (8-bit)
0	0
2	61
4	102
6	150
8	215
10	255

---

However, this is not the only problem we have to deal with.

Most real systems also demonstrate characteristics which vary with time.

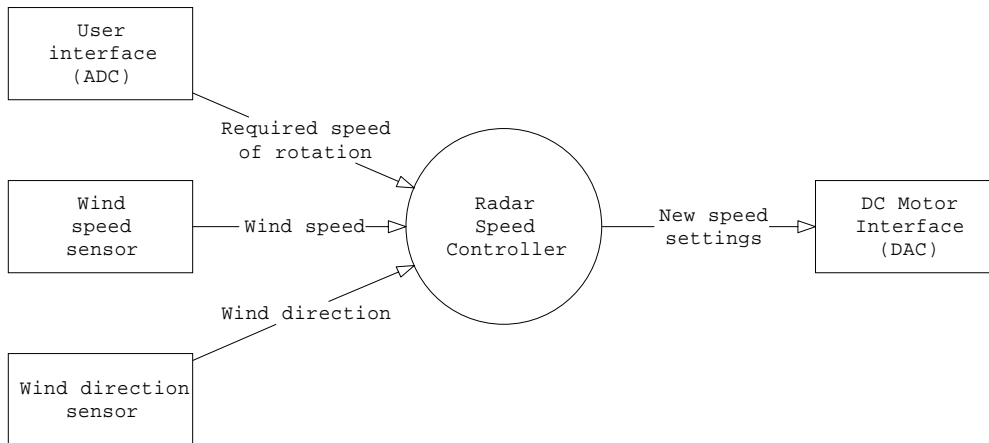

Overall, this approach to control system design quickly becomes impractical.

---

## Closed-loop control

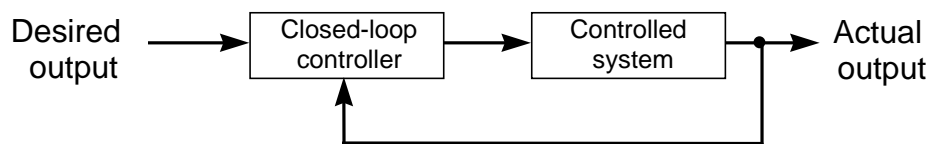
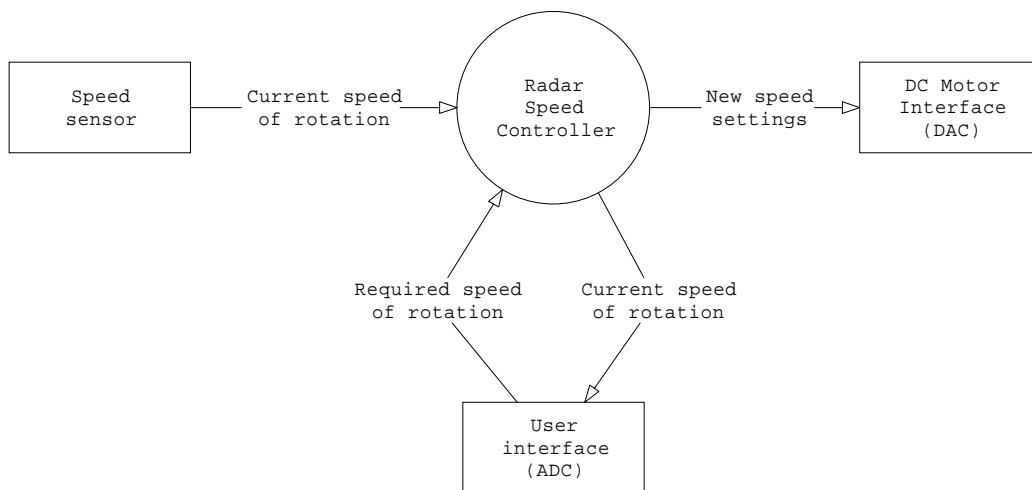

---

## What closed-loop algorithm should you use?

There are numerous possible control algorithms that can be employed in the box marked ‘Closed-loop controller’ on the previous slide, and the development and evaluation of new algorithms is an active area of research in many universities.

A detailed discussion of some of the possible algorithms available is given by Dutton *et al.*, (1997), Dorf and Bishop (1998) and Nise (1995).

Despite the range of algorithms available, Proportional-Integral-Differential (PID) control is found to be very effective in many cases and - as such - it is generally considered the ‘standard’ against which alternative algorithms are judged.

Without doubt, it is the most widely used control algorithm in the world at the present time.



---

## What is PID control?

If you open a textbook on control theory, you will encounter a description of PID control containing an equation similar to that shown below:

Where:

- $u(k)$  is the signal sent to the plant, and  $e(k)$  is the error signal, both at sample  $k$ ;
- $T$  is the sample period (in seconds), and  $1/T$  is the sample rate (in Hz);
- $K$  is the proportional gain;
- $1/T_I$  is the integral gain;
- $T_D$  is the derivative gain;

This may appear rather complex, but can - in fact - be implemented very simply.

---

## A complete PID control implementation

```
/* Proportional term */
Change_in_controller_output = PID_KP * Error;

/* Integral term */
Sum += Error;
Change_in_controller_output += PID_KI * Sum;

/* Differential term */
Change_in_controller_output += (PID_KD * SAMPLE_RATE * (Error -
Old_error));
```

---

## Another version

```
float PID_Control(float Error, float Control_old)
{
    /* Proportional term */
    float Control_new = Control_old + (PID_KP * Error);

    /* Integral term */
    Sum_G += Error;
    Control_new += PID_KI * Sum_G;

    /* Differential term */
    Control_new += (PID_KD * SAMPLE_RATE * (Error - Old_error_G));

    /* Control_new cannot exceed PID_MAX or fall below PID_MIN */
    if (Control_new > PID_MAX)
    {
        Control_new = PID_MAX;
    }
    else
    {
        if (Control_new < PID_MIN)
        {
            Control_new = PID_MIN;
        }
    }

    /* Store error value */
    Old_error_G = Error;

    return Control_new;
}
```

---

## Dealing with 'windup'

```
float PID_Control(float Error, float Control_old)
{
    /* Proportional term */
    float Control_new = Control_old + (PID_KP * Error);

    /* Integral term */
    Sum_G += Error;
    Control_new += PID_KI * Sum_G;

    /* Differential term */
    Control_new += (PID_KD * SAMPLE_RATE * (Error - Old_error_G));

    /* Optional windup protection - see text */
    if (PID_WINDUP_PROTECTION)
    {
        if ((Control_new > PID_MAX) || (Control_new < PID_MIN))
        {
            Sum_G -= Error; /* Don't increase Sum... */
        }
    }

    /* Control_new cannot exceed PID_MAX or fall below PID_MIN */
    if (Control_new > PID_MAX)
    {
        Control_new = PID_MAX;
    }
    else
    {
        if (Control_new < PID_MIN)
        {
            Control_new = PID_MIN;
        }
    }

    /* Store error value */
    Old_error_G = Error;

    return Control_new;
}
```

---

## Choosing the controller parameters

Two aspects of PID control algorithms deter new users. The first is that the algorithm is seen to be ‘complex’: as we have demonstrated above, this is a fallacy, since PID controllers can be very simply implemented.

The second concern lies with the tuning of the controller parameters. Fortunately, such concerns are - again - often exaggerated.

We suggest the use of the following methodology to tune the PID parameters:

1. Set the integral (KI) and differential (KD) terms to 0.
2. Increase the proportional term (KP) slowly, until you get continuous oscillations.
3. Reduce KP to half the value determined above.
4. If necessary, experiment with small values of KD to damp-out ‘ringing’ in the response.
5. If necessary, experiment with small values of KI to reduce the steady-state error in the system.
6. Always use windup protection if using a non-zero KI value.

Note that steps 1-3 of this technique are a simplified version of the Ziegler-Nichols guide to PID tuning; these date from the 1940s (see Ziegler and Nichols, 1942; Ziegler and Nichols, 1943).

---

## What sample rate?

One effective technique involves the measurement of the system rise time.

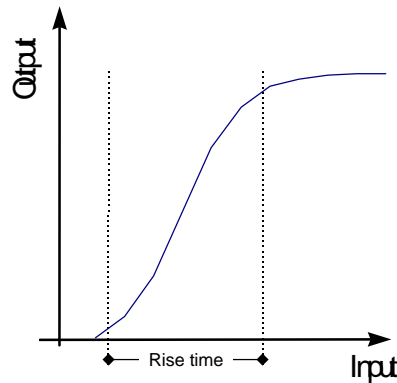

Having determined the rise time (measured in seconds), we can - making some simplifying assumptions - calculate the required sample frequency as follows:

$$\text{Sample frequency} = \boxed{\phantom{0.01}}$$

Thus, if the rise time measured was 0.1 second, the required sample frequency would be around 400 Hz.

Please note that this value is **approximate**, and involves several assumptions about the nature of the system. See Franklin et al. (1994), for further details.

---

## Hardware resource implications

- Implementation of a PID control algorithm requires some floating-point or integer mathematical operations.
- The precise load will vary with the implementation used, but a typical implementation requires 4 multiplications, 3 additions and 2 subtractions.
- With floating-point operations, this amounts to a total of approximately 2000 instructions (using the Keil compiler, on an 8051 without hardware maths support).
- This operation can be carried out every millisecond on a standard (12 osc / instruction) 8051 running at 24 MHz, if there is no other CPU-intensive processing to be done.
- A one-millisecond loop time is more than adequate for most control applications, which typically require sample intervals of several hundred milliseconds or longer.
- Of course, if you require higher performance, then many more modern implementations of the 8051 microcontroller can provide this.
- Similarly, devices such as the Infineon 517 and 509, which have hardware maths support, will also execute this code more rapidly, should this be required.

---

## **PID: Overall strengths and weaknesses**

- ☺ **Suitable for many single-input, single-output (SISO) systems.**
- ☺ **Generally effective.**
- ☺ **Easy to implement.**
- ☹ Not (generally) suitable for use in multi-input or multi-output applications.
- ☹ Parameter tuning can be time consuming.



---

## Why open-loop controllers are still (sometimes) useful

- Open-loop control still has a role to play.
- For example, if we wish to control the speed of an electric fan in an automotive air-conditioning system, we may not need precise speed control, and an open-loop approach might be appropriate.
- In addition, it is not always possible to directly measure the quantity we are trying to control, making closed-loop control impractical.
- For example, in an insulin delivery system used for patients with diabetes, we are seeking to control levels of glucose in the bloodstream. However, glucose sensors are not available, so an open-loop controller must be used; please see Dorf and Bishop (1998, p. 22) for further details.

[Similar problems apply throughout much of the process industry, where sensors are not available to determine product quality.]

---

## Limitations of PID control

- PID control is only suitable for ‘single-input, single-output’ (SISO) systems, or for system that can be broken down into SISO components.
- PID control is not suitable for systems with multiple inputs and / or multiple outputs.
- In addition, even for SISO systems, PID can only control a single system parameter’ it is not suitable for multi-parameter (sometimes called multi-variable) systems.

Please refer to Dorf and Bishop (1998), Dutton *et al.*, (1997), Franklin *et al.*, (1994), Franklin *et al.*, (1998) and Nise (1995) for further discussions on multi-input, multi-output and multi-parameter control algorithms.

---

## Example: Tuning the parameters of a cruise-control system

In this example, we take a simple computer simulation of a vehicle, and develop an appropriate cruise-control system to match.

```
#include <iostream.h>
#include <fstream.h>
#include <math.h>
#include "PID_f.h"

/* ----- Private constants ----- */

#define MS_to_MPH (2.2369)    /* Convert metres/sec to mph */

#define FRIC (50)           /* Friction coeff- Newton Second / m */
#define MASS (1000)        /* Mass of vehicle (kgs) */
#define N_SAMPLES (1000)   /* Number of samples */
#define ENGINE_POWER (5000) /* N */
#define DESIRED_SPEED (31.3f) /* Metres/sec [* 2.2369 -> mph] */

int main()
{
    float Throttle = 0.313f; /* Throttle setting (fraction) */
    float Old_speed = DESIRED_SPEED, Old_throttle = 0.313f;
    float Error, Speed, Accel, Dist;
    float Sum = 0.0f;

    /* Open file to store results */
    fstream out_FP;
    out_FP.open("pid.txt", ios::out);

    if (!out_FP)
    {
        cerr << "ERROR: Cannot open an essential file.";
        return 1;
    }
}
```

---

```

for (int t = 0; t < N_SAMPLES; t++)
{
    /* Error drives the controller */
    Error = (DESIRED_SPEED - Old_speed);

    /* Calculate throttle setting */
    Throttle = PID_Control(Error, Throttle);
    /* Throttle = 0.313f; - Use for open-loop demo */

    /* Simple car model */
    Accel = (float)(Throttle * ENGINE_POWER
        - (FRIC * Old_speed)) / MASS;
    Dist = Old_speed + Accel * (1.0f / SAMPLE_RATE);
    Speed = (float) sqrt((Old_speed * Old_speed)
        + (2 * Accel * Dist));

    /* Disturbances */
    if (t == 50)
    {
        Speed = 35.8f; /* Sudden gust of wind into rear of car */
    }

    if (t == 550)
    {
        Speed = 26.8f; /* Sudden gust of wind into front of car */
    }

    /* Display speed in miles per hour */
    cout << Speed * MS_to_MPH << endl;
    out_FP << Speed * MS_to_MPH << endl;

    /* Ready for next loop */
    Old_speed = Speed;
    Old_throttle = Throttle;
}

return 0;
}

```

---

## Open-loop test

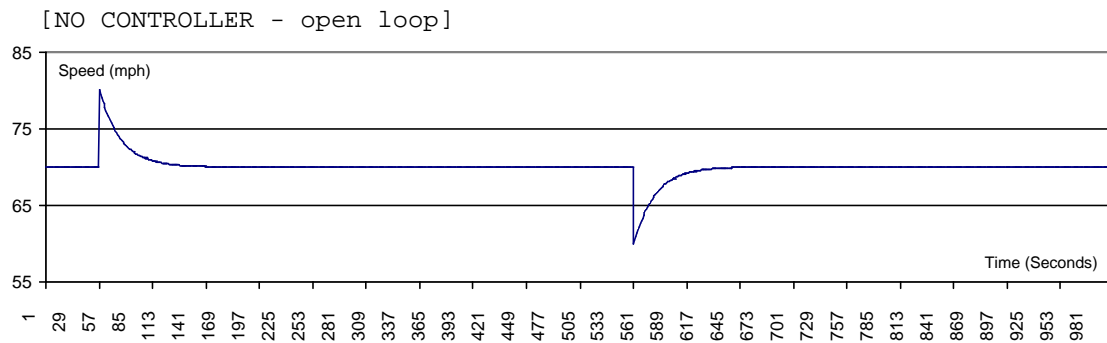

- The car is controlled by maintaining a fixed throttle position at all times. Because we assume the vehicle is driving on a straight, flat, road with no wind, the speed is constant (70 mph) for most of the 1000-second trip.
- At time  $t = 50$  seconds, we simulate a sudden gust of wind at the rear of the car; this speeds the vehicle up, and it slowly returns to the set speed value.
- At time  $t = 550$  seconds, we simulate a sharp gust of wind at the front of the car; this slows the vehicle down.

---

## Tuning the PID parameters: methodology

We will tune a PID algorithm for use with this system by applying the following methodology:

1. Set integral (KI) and differential (KD) terms to 0.
2. Increase the proportional term (KP) slowly, until you get continuous oscillations.
3. Reduce KP to half the value determined above.
4. If necessary, experiment with small values of KD to damp-out 'ringing' in the response.
5. If necessary, experiment with small values of KI to reduce the steady-state error in the system.
6. Always use windup protection if using a non-zero KI value.

---

## First test

```
#define PID_KP (0.20f)
#define PID_KI (0.00f)
#define PID_KD (0.00f)
```

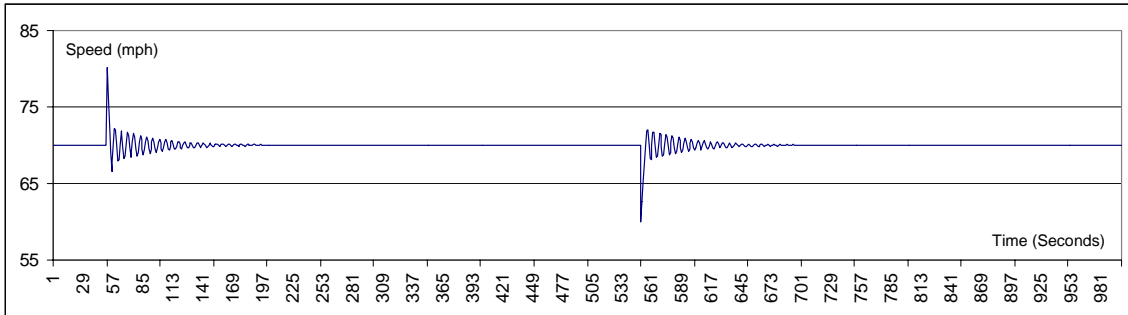

Now we increase the value of KP, until we small, constant, oscillations.

```
#define PID_KP (1.00f)
#define PID_KI (0.00f)
#define PID_KD (0.00f)
```

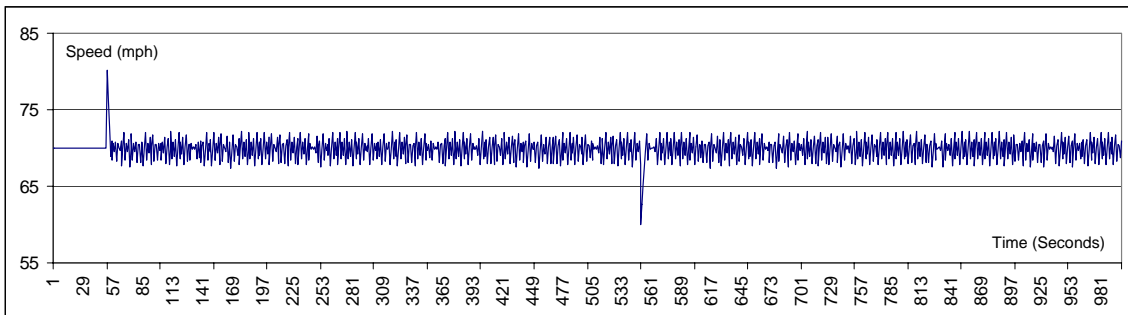

---

The results of this experiment suggest that a value of  $K_P = 0.5$  will be appropriate (that is, half the value used to generate the constant oscillations).

```
#define PID_KP (0.50f)
#define PID_KI (0.00f)
#define PID_KD (0.00f)
```

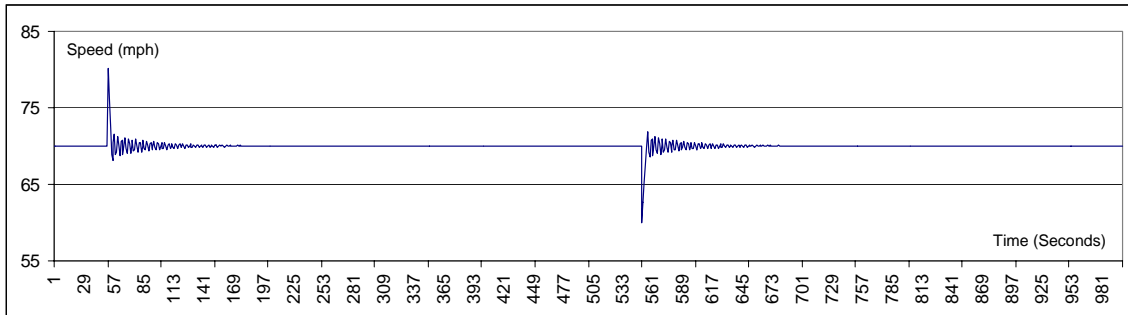

We then experiment a little more:

```
#define PID_KP (0.50f)
#define PID_KI (0.00f)
#define PID_KD (0.10f)
```

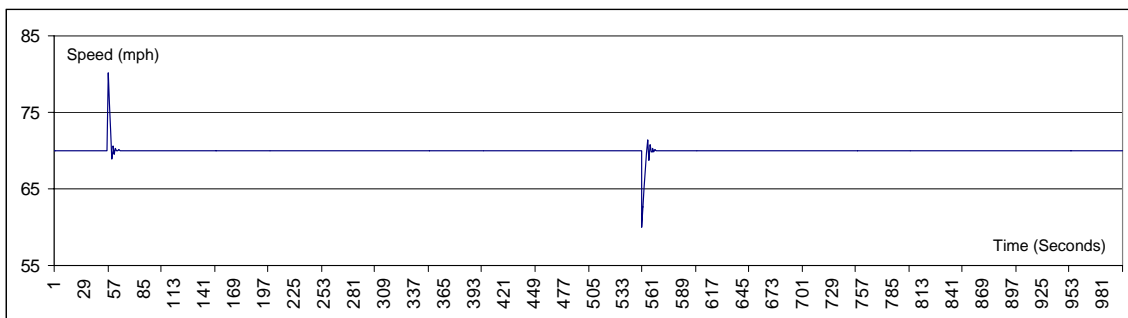

- Note that, with these parameters, the system reaches the required speed within a few seconds of each disturbance.
- Note also that we can reduce the system complexity here by omitting the integral term, and using this PD controller.



## Example: DC Motor Speed Control

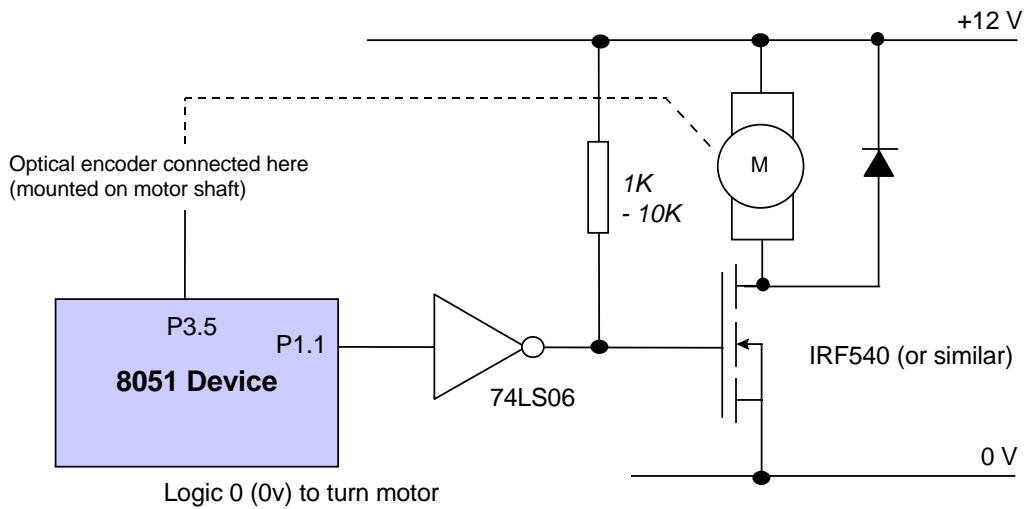

Note that this example uses a different, integer-based, PID implementation. As we discussed in 'Hardware resource implications', integer-based solutions impose a lower CPU load than floating-point equivalents.

---

```

void main(void)
{
    SCH_Init_T1(); /* Set up the scheduler */
    PID_MOTOR_Init();

    /* Set baud rate to 9600, using internal baud rate generator */
    /* Generic 8051 version */
    PC_LINK_Init_Internal(9600);

    /* Add a 'pulse count poll' task */
    /* TIMING IS IN TICKS (1ms interval) */
    /* Every 5 milliseconds (200 times per second) */
    SCH_Add_Task(PID_MOTOR_Poll_Speed_Pulse, 1, 1);

    SCH_Add_Task(PID_MOTOR_Control_Motor, 300, 1000);

    /* Sending data to serial port */
    SCH_Add_Task(PC_LINK_Update, 3, 1);

    /* All tasks added: start running the scheduler */
    SCH_Start();

    while(1)
    {
        SCH_Dispatch_Tasks();
    }

    ...

#define PULSE_HIGH (0)
#define PULSE_LOW (1)

#define PID_PROPORTIONAL (5)
#define PID_INTEGRAL (50)
#define PID_DIFFERENTIAL (50)

```

---

```

void PID_MOTOR_Control_Motor(void)
{
    int Error, Control_new;

    Speed_measured_G = PID_MOTOR_Read_Current_Speed();
    Speed_required_G = PID_MOTOR_Get_Required_Speed();

    /* Difference between required and actual speed (0-255) */
    Error = Speed_required_G - Speed_measured_G;

    /* Proportional term */
    Control_new = Controller_output_G + (Error / PID_PROPORTIONAL);

    /* Integral term [SET TO 0 IF NOT REQUIRED] */
    if (PID_INTEGRAL)
    {
        Sum_G += Error;
        Control_new += (Sum_G / (1 + PID_INTEGRAL));
    }

    /* Differential term [SET TO 0 IF NOT REQUIRED] */
    if (PID_DIFFERENTIAL)
    {
        Control_new += (Error - Old_error_G) / (1 + PID_DIFFERENTIAL);

        /* Store error value */
        Old_error_G = Error;
    }

    /* Adjust to 8-bit range */
    if (Control_new > 255)
    {
        Control_new = 255;
        Sum_G -= Error; /* Windup protection */
    }

    if (Control_new < 0)
    {
        Control_new = 0;
        Sum_G -= Error; /* Windup protection */
    }

    /* Convert to required 8-bit format */
    Controller_output_G = (tByte) Control_new;

    /* Update the PWM setting */
    PID_MOTOR_Set_New_PWM_Output(Controller_output_G);
    ...
}

```

---

## **Alternative: Fuzzy control**

Most available textbooks highlight traditional (mathematically-based) approaches to the design of control systems.

A less formal approach to control system design has emerged recently: this is known as ‘fuzzy control’ and is suitable for SISO, MISO and MIMO systems, with one or more parameters.

(Refer to Passino and Yurkovich, 1998, for further information on fuzzy control.)

---

## Preparations for the next seminar

In the final seminar on this course we'll discuss a case study which will pull together some of the key material we have considered in this (and earlier) seminars.

Please review your notes before the final seminar.



---

**Seminar 10:**  
Case study:  
Automotive cruise  
control using PID and  
CAN

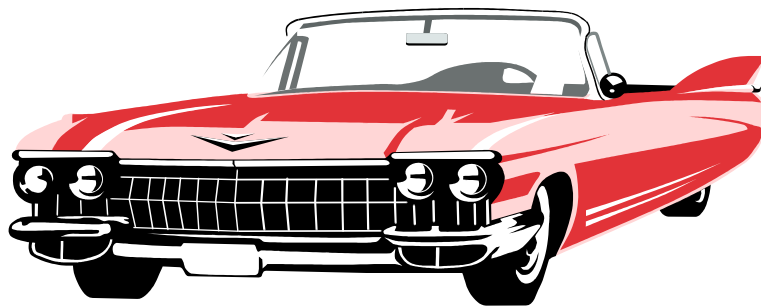

---

## Overview of this seminar

We have considered the design of schedulers for multi-processor distributed systems in this module, and looked - briefly - at some elements of control-system design.

In this session, we take the simple cruise-control example discussed in Seminar 8 and convert this into a complete - distributed - system.

We will then use the resulting system as a testbed to explore the impact of **network delays** on distributed embedded control systems.

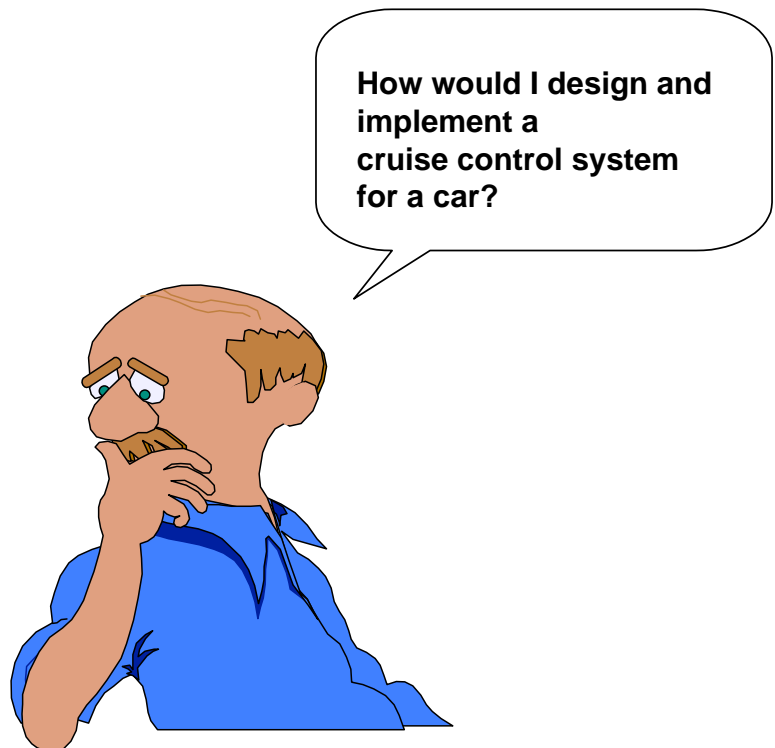



---

## Single-processor system: Overview

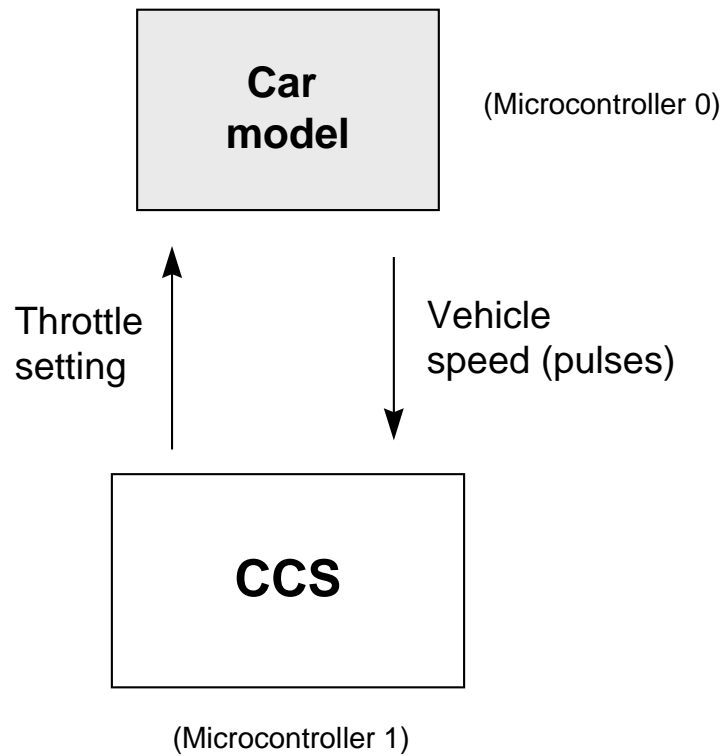

---

## Single-processor system: Code

[We'll discuss this in the seminar]

---

## Multi-processor design: Overview

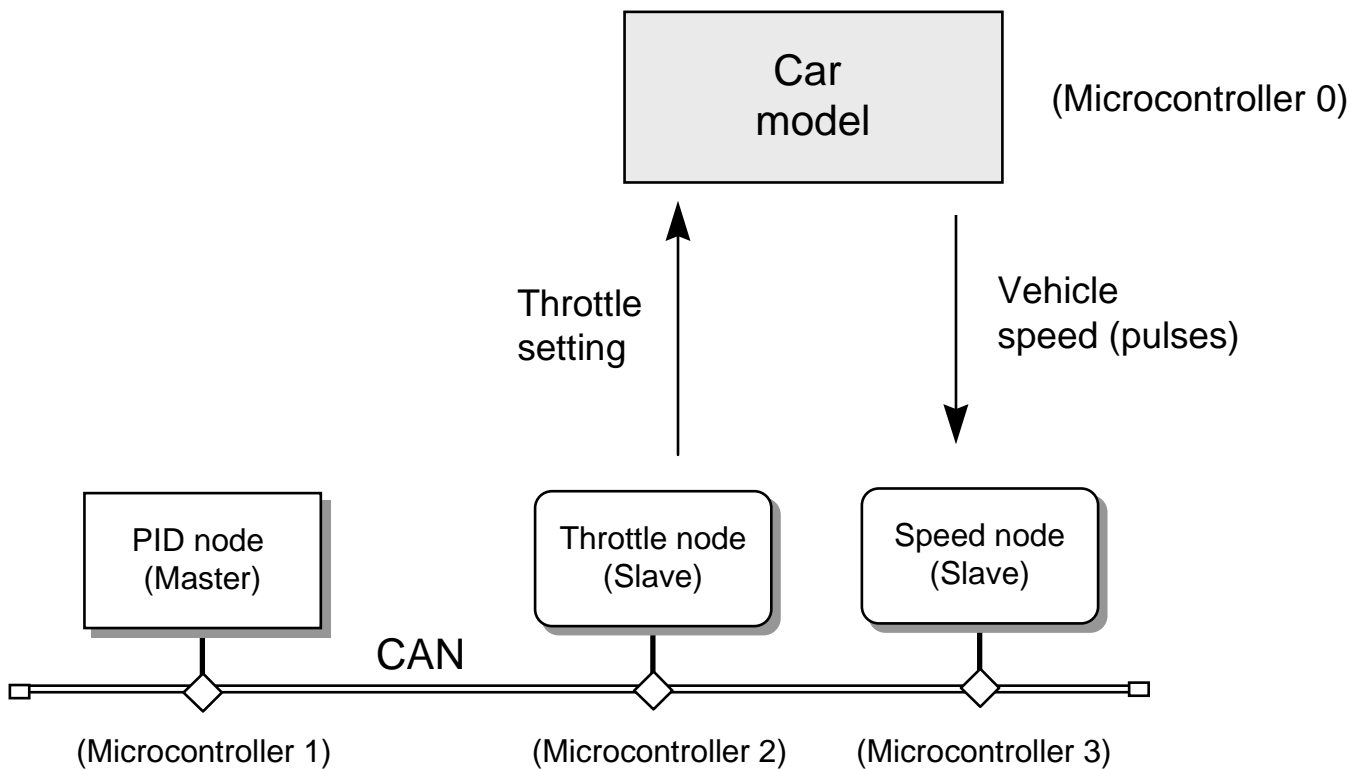

---

## Multi-processor design: Code (PID node)

[We'll discuss this in the seminar]

---

## Multi-processor design: Code (Speed node)

[We'll discuss this in the seminar]

---

## Multi-processor design: Code (Throttle node)

[We'll discuss this in the seminar]

---

## Exploring the impact of network delays

- We discussed in the last seminar how we can calculate the required sampling rate for a control system.
- When developing a distributed control system, we also need to take into account the **network delays**.

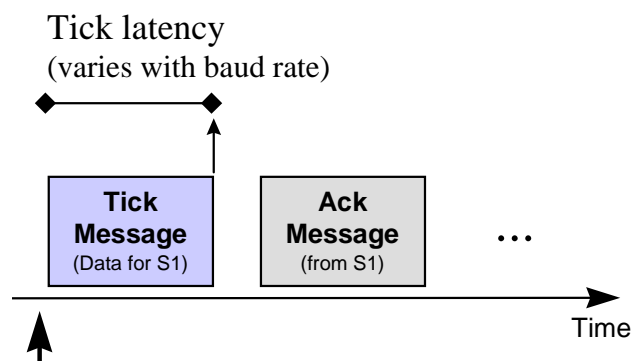

- This is a complex topic...
- Two effective “rules of thumb”:
  - ◇ Make sure the delays are **short**, when compared with the sampling interval. Aim for **no more than 10%** of the sample interval between sensing (input) and actuation (output).
  - ◇ Make sure the delays are constant - **avoid “jitter”**.

---

## Example: Impact of network delays on the CCS system

[We'll discuss this in the seminar - and you will try it in the lab.]



---

**That's it!**

This seminar brings us to the end of the course - I hope that you have enjoyed it (and found it useful).